

A STUDY TO COPPER MINES & INDUSTRIES WITH AN OUTLOOK TO IRAN MARKET



By:

Ali Bakhtiari Ghaleh-Elham Kordzadeh

Independent Researchers

May-July 2016

Contents

1. INTRODUCTION.....	
2. COPPER HISTORY.....	
3. APPLICATION OF COPPER	
4. COPPER IMPORTANCE AND ADVANTAGES.....	
5. COPPER ALLOYS FAMILIES	
6. COPPER SOURCES AND SUPPLY	
6.1. MAIN COPPER MINES IN THE WORLD.....	
6.1.1. ESCONDIDA, CHILE.....	
6.1.2. CANANEA, MEXICO.....	
6.1.3. COLLAHUASI, CHILE	
6.1.4. ANDINA, CHILE.....	
6.1.5. TOQUEPALA, PERU	
6.1.6. EL TIENIENTE, CHILE	
6.1.7. CERRO VERDE, PERU.....	
6.1.8. RADOMIRO TOMIC, CHILE	
6.1.9. LOS BRONCES, CHILE	
6.1.10. GRASBERG, INDONESIA	
6.2. IRAN COPPER SOURCES	
6.2.1. GREATER CAUCASUS AND NORTHERN IRAN	
6.2.2. EASTERN AND CENTRAL_EASTERN IRAN	
6.2.3. CENTRAL AND SOUTHEASTERN IRAN.....	
6.2.4. SOUTHEASTERN IRAN AND SOUTHWESTERN PAKISTAN.....	
6.3. MAIN COPPER MINES OF IRAN	
6.3.1. MIDUK COPPER MINE.....	
6.3.2. SARCHESHMEH COPPER MINE	
6.3.3. SUNGOUN COPPER MINE	
6.3.4. DARREH ALOU COPPER MINE.....	
6.3.5. CHAH FIROUZEH COPPER MINE	
6.3.6. EJOU COPPER MINE.....	
6.3.7. DARREH ZAR MINE	
6.3.8. DARE ZERESHK COPPER MINE	

6.3.9. NOCHOUN COPPER MINE.....	
6.3.10. MASJED DAGHI	
6.3.11. KAHANG	
6.3.12. HAFT CHESHMEH	
6.3.13. ALI ABAD COPPER MINE	
6.3.14. SERENU	
6.3.15. SERIDUN.....	
7. COPPER PRODUCTION.....	
7.1. EXTRACTION	8
7.1.1. SURFACE MINING METHODS	8
7.1.2 UNDERGROUND MINING METHODS.....	10
7.2. BENEFICIATION OPERATIONS.....	12
7.2.1 CONVENTIONAL MILLING	13
7.3. HYDROMETALLURGY.....	60
7.3.1. LEACH OPERATIONS (IN SITU, DUMP, HEAP AND VAT)	20
7.4. PYROMETALLURGY EXTRACTION	36
7.4.1. BLAST FURNACE SMELTING.....	36
7.4.2. REVERBERATORY FURNACE SMELTING.....	38
7.4.3. FLASH FURNACE SMELTING.....	40
7.5. CASTING	41
7.6. FABRICATION OF TUBES, SECTIONS AND RODS.....	41
7.7. FABRICATION OF SHEETS AND STRIPS	43
8. SHAPPING PROCESS.....	44
8.1. EXTRUSION	44
8.1.1. DIRECT EXTRUSION.....	44
8.1.2. INDIRECT EXTRUSION	45
8.1.3. EXTRUSION OVER A MANDREL.....	45
8.2. DRAWING.....	46
9. COPPER PRODUCTS.....	46
9.1. CONCENTRATE.....	46
9.2. MATT.....	47
9.3. BLISTER	47

9.4. ANODE	48
9.5. CATHODE	48
9.6. SEMI FINISHED AND FINISHED PRODUCTS	49
9.6.1. RODS	49
9.6.2. PIPE & TUBE	49
9.6.3. WIRES.....	57
9.6.4. SECTIONS	57
10. COPPER BY PRODUCTS	57
11. COPPER RECYCLE.....	57
11.1. BENEFITS OF RECYCLING COPPER	62
11.2. PRETREATMENT OF SCRAP COPPER.....	64
11.3. METHODS OF COPPER SCRAP RECYCLING	65
11.4. COPPER SCRAP SOURCES.....	66
11.5. EUROPE DEMAND FOR RECYCLED COPPER.....	68
12. COPPER PRODUCTION	70
12.1. WORLD COPPER PRODUCTION	70
12.2. IRAN COPPER PRODUCTION	75
12.2.1. IRAN COPPER CONCENTRATE.....	76
12.2.2. IRAN COPPER COMPLEXES	77
12.2.3. IRAN COPPER SEMIFINISHED AND FINISHED PRODUCERS.....	81
12.2.3.1. BAHONAR COPPER COMPLEX INDUSTRIES	81
12.2.3.2. SHAHR BABAK COPPER TUBE INDUSTRIES.....	88
12.2.3.3. COPPER WORLD COMPANY	89
12.2.3.4. MEHRASL	90
12.2.3.5. QAEM COPPER INDUSTRIES	91
12.2.3.6. KAVEH COPPER COMPANY.....	92
12.2.3.7. MESBAR KAVEH COPPER COMPANY	92
12.2.3.8. MESKARAN COPPER COMPANY	92
12.2.3.9. OFOGHE ALBORZ COMPANY	92
12.2.3.10. SIMKAT TABRIZ COMPANY	92
12.2.3.10. ELECTRO MES COMPANY	92

13. SUPPLY AND DEMAND.....	93
14. COPPER IMPORT & EXPORT	95
15. COPPER PRICES.....	100
16. DEVELOPMENT PLANS.....	103
16.1. KHATOON ABAD SMELTER EXPANSION	103
16.2. SARCHESHMEH NICKEL PLANT	103
16.3. CHEHEL KOREH COPPER PROGRAM.....	103
16.4. MAHURE CHAH KALEH PROSPECT.....	104
16.5. LORDKHIZAN PROSPECT	104
16.6. THE GROUH PROSPECT.....	104
16.7. SINABAD PROSPECT.....	104
16.8. ZAVORK PROSPECT	104
16.9. RAZI ABAD PROSPECT.....	105
16.10. DAREH HAMZEH PROSPECT	105
16.11. PURCHANGI PROSPECT	105
16.12. BIDESSTAR PROSPECT.....	105
16.13. BAGH GOLAN PROSPECT	105
16.14. BAB SHAMIL PROSPECT	106
16.15. BAGH GOLAN PROSPECT	106
16.16. LAR DEPOSIT	106
16.17. KAHANG DEPOSIT	106
16.18. KHATOON ABAD REFINERY PLANT	106
16.19. KHATOON ABAD ACID SULFURIC PLANT.....	107
16.20. KHATOON ABAD OXYGEN PLANT	107
16.21. KHATOON ABAD OXYGEN PLANT	107
16.22. SARCHESHMEH BENEFICIATION EXPANSION_PHASE 2	107
16.23. SARCHESHMEH BENEFICIATION EXPANSION_PHASE 3	107
16.23. SUNGUN BENEFICIATION EXPANSION_PHASE 2.....	108
16.24. MIDUKN BENEFICIATION EXPANSION_PHASE 2	108
16.25. SUNGUN BENEFICIATION EXPANSION_PHASE 3.....	108
16.26. SARCHESHMEH SLAG FLOTATION	108

16.27. SUNGUN SLAG FLOTATION.....	108
16.28. KHATOONABAD EXPANSION OF SMELTING.....	109
16.29. KHATOONABAD SULPHURIC ACID PLANT	109
16.30. SUNGUN SMELTING PLANT	109
16.31. SUNGUN SULPHURIC ACID PLANT.....	109
16.32. SUNGUN REFINERY PLANT	109
16.33. KHATOONABAD REFINERY PLANT	109
17. CONCLUSION.....	149

7. COPPER PRODUCTION

About 80% of primary copper production comes from low-grade or poor sulfide ores. After enrichment steps, the copper concentrates are usually treated by pyrometallurgical or hydrometallurgical methods. [12]

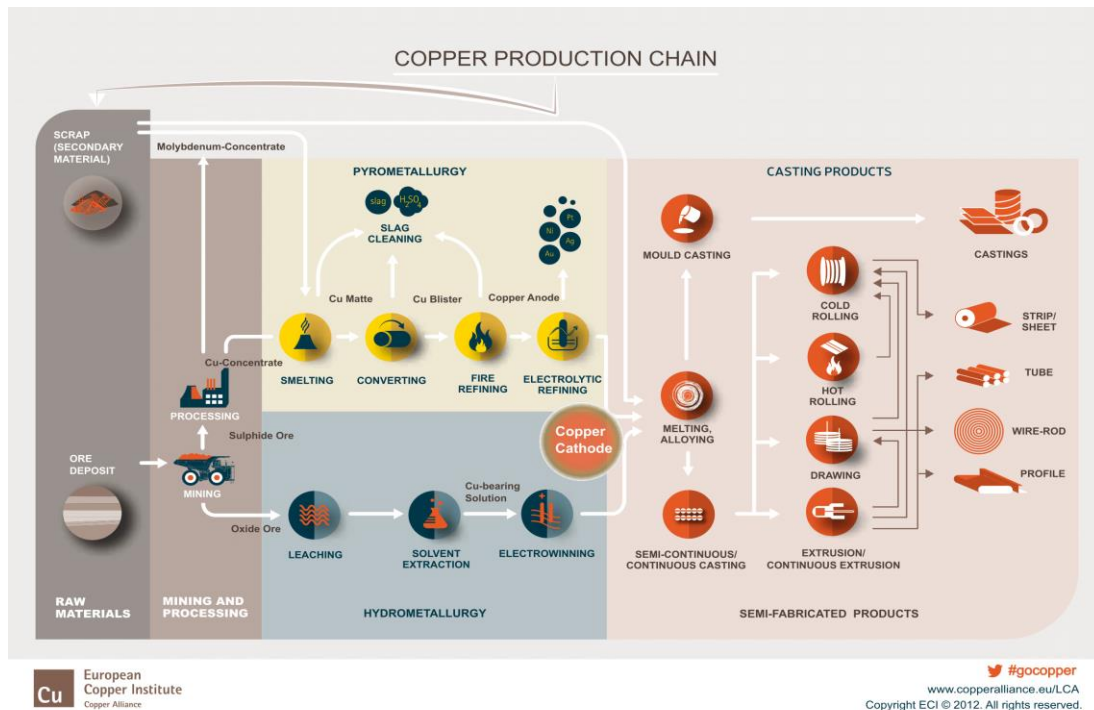

Figure 43. Copper Production Chain
Source: European Copper Institute Copper Alliance

Generally, copper extraction follows the sequence:

7.1. EXTRACTION

Extraction is the operation of physically removing ore from deposits in the earth. There are three basic methods of extracting copper ore: surface, underground, and solution mining.

Surface and underground mines usually operate independently of each other, although underground techniques are sometimes used before and/or after surface methods. Some open-pit surface operations extract massive sulfide deposits and intersect abandoned underground workings that were closed due to the low grade (or lack) of oxide and sulfide ore.

Open-pit mining is the predominant method used today by the copper mining industry. This is due primarily to inherently high production rates, relative safety, low costs, and flexibility in extraction.

Underground mining operations are used to mine deeper, and richer ore bodies. Factors influencing the choice of mining method include the size, shape, dip, continuity, depth, and grade of the ore body; topography; tonnage; ore reserves; and geographic location.

Solution mining of copper oxide and sulfide ores has increased since 1975. In this method, dilute sulfuric acid is percolated through ore contained in dumps, on leach pads, or underground leaching of broken rubble in or around formerly active stopes. Experimental work on in situ leaching, where the ore is leached in place, is also being conducted. The copper-bearing pregnant leach solution (PLS) is collected, and copper is recovered by SX/EW or precipitation methods. Solution mining has enabled facilities to beneficiate lower grade sulfide and oxide ores.

7.1.1. SURFACE MINING METHODS

As indicated above, most copper is produced by surface mining methods. Surface mining involves the excavation of ore from the surface by removing overburden (nonmineralized soil and rock that cover an ore body) and waste rock (poorly mineralized or very low-grade soil and rock that are within the ore body or surrounding it) to expose higher-grade minerals.



Figure 44. Open Pit Mine

Source: mining-technology.com

In general, overburden is removed as efficiently and rapidly as possible, usually with little comminution. Overburden piles compose the largest volume of wastes generated by surface extraction activities.

Advantages of surface mining operations, as compared to underground operations, include flexibility in production rates without deterioration of workings, relative safety for workers, ability to practice selective mining and grade control, and low cost per ton of ore recovered. Surface mining also has lower development and maintenance costs than underground mining because it requires fewer specialized systems. During expanded development, however, some surface mines with large amounts of prestripping waste could have higher costs than established underground mines.

Open-pit mining is most common in the copper mining industry because the ore body being mined is large and the overburden depth is usually limited. Open-pit mine designs are based on the configuration of the ore body, the competence of the rock, and other factors. The mine shape is formed by a series of benches or terraces arranged in a spiral or in levels with interconnecting ramps. Open-pit mines may reach several thousand feet below the surface.

In the development stage, overburden is stripped off to expose the ore. The waste and ore are excavated by drilling rows of 6 to 12 inch (diameter) blast holes. Samples from the blast holes are analyzed to determine the grade. The blast holes are filled with a mixture of ammonium nitrate and fuel oil (ANFO) type explosive.

Most mining operations use nonelectric caps and delays to control the blasting sequence.

Usually, an entire segment of a bench is "shot" at one time. Subsequently, large electric or diesel shovels or front-end loaders transport the ore onto trucks, trains, or conveyor belts for removal to milling or leaching facilities, depending on the type of ore (sulfide or oxide) and grade. A pneumatic or hydraulic impact hammer, similar to a jackhammer, is used to break up waste and ore too large to handle in the pit or in subsequent crushing operations.

7.1.2 UNDERGROUND MINING METHODS

Underground mining methods are usually employed to mine richer, deeper, and smaller ore bodies where open-pit methods would be impractical. Underground mining operations are complex combinations of tunneling, rock support, ventilation, electrical systems, water control, and hoists for the transportation of people, ore, and materials.



Figure 45. Underground Mine

Source: mining.com

The three main underground mining methods used to mine copper ore are stoping, room-and-pillar, and block caving. All of these methods can be used in several variations, depending on the characteristics of the ore body.

In general, all these underground operations involve sinking a vertical shaft or driving a horizontal adit, both of which provide access to the ore body.

This type of extraction technique is best adapted to steeply dipping vein-type deposits. Today, underground operations using stoping methods are usually byproduct producers of copper and have relatively low copper tonnages.

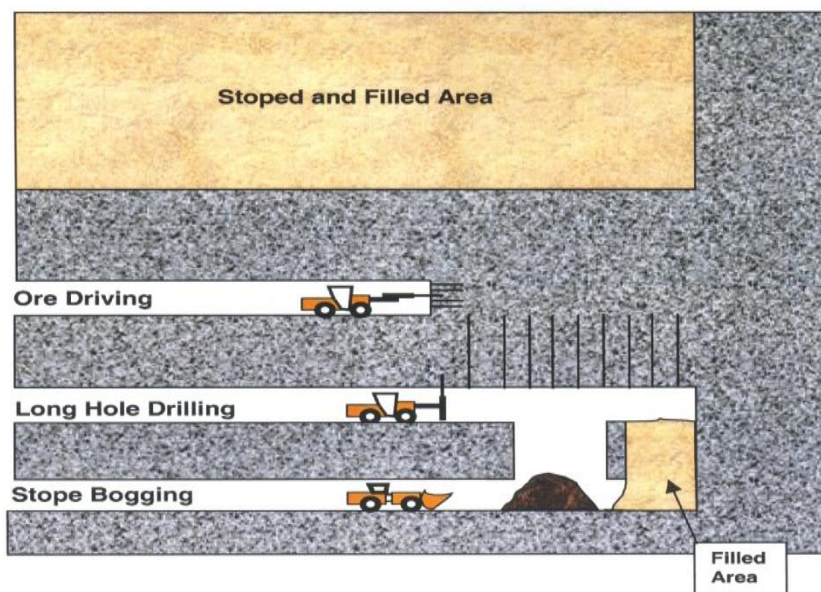

Figure 46. Stoped and Filled Area

Source: nvp-pgf.org

Most underground stope mines are designed with two or more shafts and a series of parallel drifts, known as levels, which intersect the main shaft. Ore mining occurs in areas between adjacent levels in irregular cavities called stopes.

The stopes are connected to the levels by tow raises (one on each side of the block of ore to be mined), man ways (to provide access), and chutes (to remove the ore). The ore is drilled and blasted at the face of the stope, then raked (or mucked) down a chute. The chutes are located above the main haulage drifts and intercept them. The ore is loaded onto rail or rubber tire ore cars that haul it to the shaft. It is then dumped into another chute that feeds the ore into buckets that are hoisted to the surface. Waste rock, known as mine development rock (material removed to access the ore body), is handled the same way, except that it is hauled to an adjacent stope. There, it is dumped into a raise that feeds into a stope where it is backfilled to provide a working area to drill out the next ore cut.

Room-and-pillar mining operations produce more tonnage than any other type of mine operation. Room-and pillar operations are best adapted to mining large, flat deposits or massive deposits where sequential slices or levels may be mined. Mining is conducted in a nearly horizontal or horizontal altitude.

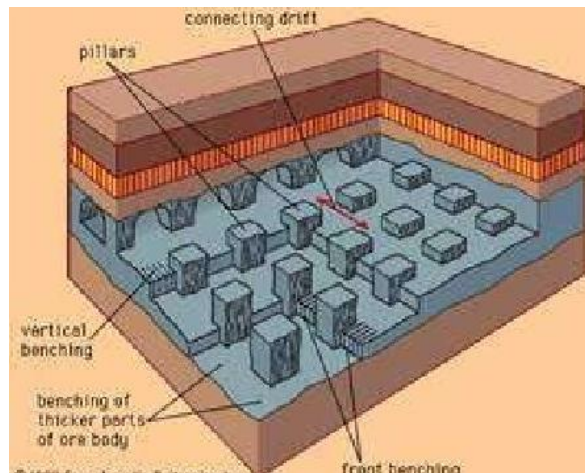

Figure 47. Rooms and Pillars

Source: slideshare.net

Depending on the access design for the deposit, vertical shafts or relatively horizontal inclines or declines may be used. A double entry system is designed to provide ventilation, men and materials access, and ore transport.

Usually, ore is mined in two phases, the first phase involves driving large horizontal drifts (called rooms) parallel to each other and smaller drifts perpendicular to the rooms. The area between the intersection of the rooms and drifts forms the pillars, which support the roof. Rooms vary in size from 6 to 60 feet high and 10 to 100 feet wide. The size of each room and pillar is dependent on the quality of the rock. Between 30 and 60 percent of the ore remains unmined in the pillars. Once the mine reaches the end of the ore body, the second phase of operations may begin to recover the ore left behind in the pillars. Starting from the back of the mine and working forward, the pillars are mined out one at a time, a technique called "pillar robbing." Timbers are used to temporarily support the roof. Once a pillar is mined out, the timbers are removed and the ground is allowed to collapse. This procedure is called "retreating" and produces ore at a relatively low cost per ton.

7.2. BENEFICIATION OPERATIONS

Beneficiation of ores and minerals is defined as including the following activities: crushing; grinding; washing; filtration; sorting; sizing; gravity concentration; flotation; ion exchange; solvent extraction; electrowinning; precipitation; amalgamation; roasting; autoclaving; chlorination; and heap, dump, tank, and in situ leaching. The beneficiation method(s) selected varies with mining operations and depends on ore characteristics and economic considerations.

7.2.1 CONVENTIONAL MILLING

The typical stages in the conventional milling/flotation of sulfide ores are as follows:

Crushing and Grinding (Comminution)

The first step in beneficiation is comminution. Typically, this is accomplished by sequential size reduction operations-commonly referred to as crushing and grinding. Crushing may be performed in two or three stages. Primary crushing systems consist of crushers, feeders, dust control systems, and conveyors used to transport ore to coarse ore storage. Primary crushing is often accomplished by a jaw or gyratory crusher, since these units can handle larger rocks.

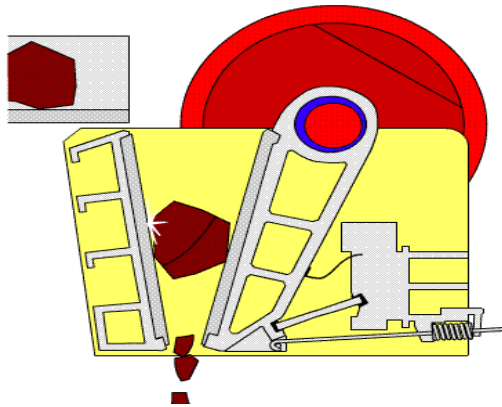

Figure 48. Jaw Crusher
Source: aggdesigns.com



Figure 49. Gyratory Crusher
Source: FLSmidth.com

Cone crushers, work best at large, high-capacity operations because they can handle larger tonnages of material. The feed to primary crushing is generally run-of-mine ore, which is reduced from large pieces (2 to 4 feet in dimension) to smaller pieces (8 to 10 inches in dimension).

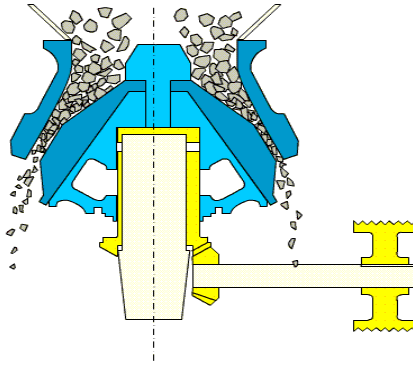

Figure 50. Cone Crusher
Source: aggdesigns.com

Primary crushing systems are typically located near or in the pit at surface mines or below the surface in underground mines. Crushed ore is then transferred to secondary crushers, usually located near the next step in beneficiation. The ore may be temporarily stored in piles at the site.

Secondary and tertiary crushing usually is performed in surface facilities in cone crushers, although roll crushing or hammer mills are sometimes used. In these reduction stages, ore must be reduced to about 0.75 inches before being transported (usually on conveyer belts) to a grinding mill.

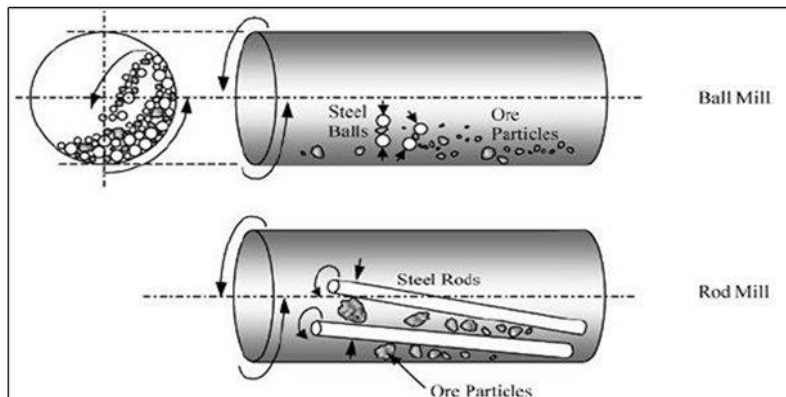

Figure 51. Ball and Rod Mill
Source: technology.infomine.com

Size separators (such as grizzlies and screens) control the size of the feed material between the crushing and grinding stages. Grizzlies are typically used for very coarse material. Screens mechanically separate ore sizes using a slotted or mesh surface that acts as a "go/no go" gauge. Vibrating and shaker screens are the most commonly used types of separators. There are many different types of vibrating screens,

designed to handle material between 25 centimeters (cm) and 5 mm. After the final screening, water is added to the crushed ore to form a slurry.

Grinding is the last stage in comminution. In this operation, ore particles are reduced and classified (typically in a hydrocyclone) into a uniformly sorted material between 20 and 200 mesh. Most copper facilities use a combination of rod and ball mills to grind sulfide ore. Rod mills use free steel rods in the rotating drum to grind the ore. A ball mill works by tumbling the ore against free steel balls and the lining of the mill. Rod and ball mills are constructed with replaceable liners composed of high-strength chromemolybdenum steel bolted onto the mill shell. The grinding face of the liner is ribbed to promote mixing. The liners require extensive maintenance and must be replaced regularly. To replace the liner, the mill must be taken out of production. A shutdown of a mill requires additional milling capacity to prevent overall mill shutdowns during.

In some cases, ore and water are fed into an autogenous mill (where the grinding media are the hard ores themselves), or a semiautogenous mill (where the grinding media are the ore supplemented by large steel balls).

Each unit in the series produces successively smaller material. Typically, crushed ore and water enter the rod mill. When the material is reduced to a certain particle size, it becomes suspended in the slurry (because of its size and specific gravity and the motion of the mill). The fine material then floats out in the overflow from the mill. At this point, the ore slurry is classified according to particle size in a hydrocyclone or similar device. Oversize material passes to the ball mill for additional grinding. Undersize material moves to the next phase of beneficiation.

After grinding, ore is pumped to a classifier designed to separate fine-grained material (less than 5 mm) from coarse-grained material requiring further grinding. This method is used to control both under and over milling or grinding. Classification is based on differences in the size, shape, density, and settling rate of particles in a liquid medium (i.e., water). Various kinds of hydraulic classifiers are used. These generally fall into two categories: horizontal and vertical current classifiers. Mechanical classifiers are horizontal current classifiers, which are no longer in wide use. The hydro cyclone is the standard technology for vertical classifiers in use today.

Flotation

The second step in the beneficiation of sulfide ore is concentration. The purpose of concentration is to separate the valuable mineral (or "values") from nonvaluable minerals (referred to as "gangue"). There are a variety of concentration methods. Selection of a method (or methods) to use for a particular ore is based on the ore mineralogy and mineral liberation size. Froth flotation is the standard method of concentration used in the copper industry. About 75 percent of all copper is produced by this method. The most significant technological development in flotation in recent years is the column flotation cell, which is being installed at most concentrators.

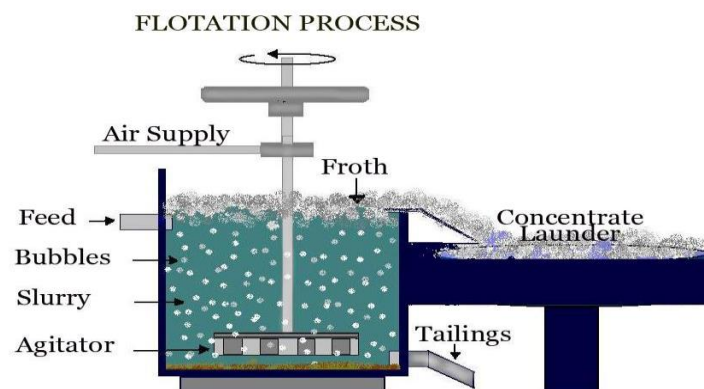

Figure 52. Froth Flotation

Source: 911metallurgist.com

One of the advantages to the flotation method is that it makes the recovery of molybdenum [as molybdenite (MoS_2)] by selective flotation viable at some properties. The recovery of molybdenite, when the molybdenum price is adequate, can provide a significant portion of a mine's revenue.

In addition to the byproduct of molybdenum, most of the precious metals in the copper concentrate are recovered in anode slimes during subsequent electro refining steps. In general, they resemble a large washing machine that keeps the particles in suspension through agitation. The ore is first conditioned with chemicals to make the copper minerals water-repellent (i.e., hydrophobic) without affecting the other minerals. Air is then pumped through the agitated slurry to produce a bubbly froth. The hydrophobic copper minerals are aerophilic that is they are attracted to air bubbles, to which they attach themselves, and then float to the top of the cell. As they reach the surface, the bubbles form a froth that overflows into a trough for collection. The minerals which sink to the bottom of the cell and are removed for disposal.

The simplest froth flotation operation is the separation of sulfide minerals from gangue minerals (such as limestone or quartz). The separation of different types of sulfide minerals, such as chalcopyrite, from pyrite is more complex, because the surfaces of the minerals have to be modified so that the reagents attach only to the mineral to be floated. In practice, each ore is unique; consequently, there is no standard flotation procedure. Once the unit is operational, continued monitoring of the ore feed mineralogy is critical to fine-tune the flotation units when changes occur. These changes occur because ore bodies are not homogeneous; variations in feed and mineralogy are normal and may require circuit modifications.

Conventional flotation is carried out in stages. The purpose of each stage depends on the types of minerals in the ore. Selective flotation of chalcocite-bearing sulfide ores and the rejection of pyrite utilizes three types of flotation cells: roughers, cleaners, and scavengers.

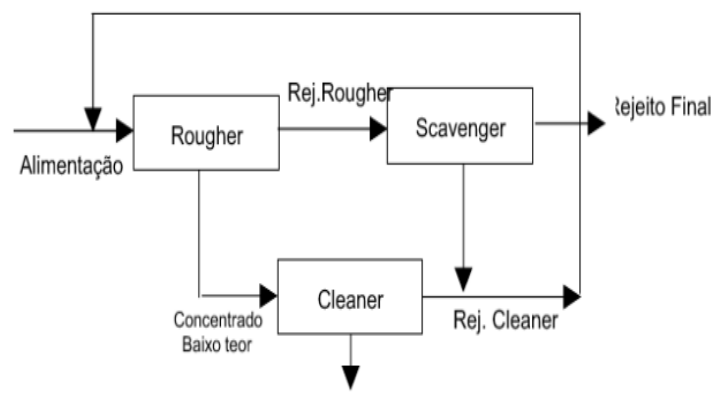

Figure 53. Conventional Flotation

Source: ebah.com.br

Roughers use a moderate separating force to float incoming ore and to produce a medium-grade concentrate. Cleaners use a low separating force to upgrade the rougher concentrate by removing additional pyrite and gangue waste material to produce a high-grade concentrate. Scavengers provide a final, strong flotation treatment for the rougher tailings by using a strong concentration of reagents and vigorous flotation to recover as much of the remaining sulfide minerals as possible. The float from the scavenger flotation is often recycled through a regrinding mill and sent back to the rougher flotation cells. Throughout the operation, the pyrite is depressed by employing a modifying agent, such as lime, for pH control.

Because flotation is partially dependent on ore particle size, regrinding of the particles between the rougher and cleaner flotation cells may be needed. Tailings from the cleaner flotation may be sent back to the flotation circuit for additional recovery.

For more complex ores, the first stage of flotation is often a bulk float. This is similar to the rougher stage, in which much of the waste and some of the byproduct metals are eliminated. The bulk concentrate goes to roughers (which float specific types of sulfides) and then to cleaners. Again, a regrinding circuit may be needed between rougher cells.

Froth flotation is carried out using reagents that, when dissolved in water, create hydrophobic forces that cause the values to float. Reagents can be added prior to entering the initial rougher flotation stage and/or during subsequent steps in the flotation operation. The reagents used in flotation concentrators are called collectors, depressants, activators, frothers, flocculants, filtering aides, and pH regulators.

A copper collector typically is composed of a complex heteropolar molecule, which has a charged (i.e., negative) sulfur-bearing polar group end and a noncharged nonpolar group end.

The nonpolar radical is a hydrocarbon that has pronounced water-repellant properties, whereas the polar group reacts with water and the copper mineral surface. The reaction between sulfide minerals and sulfide collectors (such as xanthates) results in insoluble metal xanthates that are strongly hydrophobic.

The copper sulfide mineral becomes a surface covered with air-avid hydrocarbon nonpolar ends seeking an air bubble attachment introduce air into the slurry, creating dispersed bubbles to which the hydrophobic complexes attach (and on which they then float to the surface).

Frothers are chemically similar to ionic collectors; they absorb on the air-water interface and reduce the surface tension, thus stabilizing the bubbles. The resultant froth must be short-lived and self-deteriorating or the flotation units would be enveloped in foam. Standard frothing agents used in copper and copper-molybdenite concentrators include alcohols, pine oil, and polyglycol ethers.

Differential flotation for complex ores that contain sulfides (other than copper sulfides) requires the use of reagents that modify the action of the collector either by intensifying or reducing its water-repellant effect on the valuable mineral surface. These reagents are known as modifiers or regulators or, in copper-molybdenite concentrators, as depressants and activators.

The most common modifier is the OH (hydroxyl) ion. Lime or sodium carbonate is used to raise the pH of the slurry and regulate the pulp alkalinity. The second most common modifier in copper flotation is the cyanide ion derived from sodium cyanide. It is normally used to depress pyrite while floating chalcopyrite or chalcocite in rougher flotation.

Standard activators used in the copper and copper-molybdenite flotation circuit for oxidized copper mineral surfaces are sodium sulfide and sodium hydrosulfide.

Copper mineral concentrate, the product of flotation, is then sent to a smelter for processing. The waste material or tailings from this operation is sent to a tailings pond for disposal. Copper concentrates exiting the flotation circuit contain 60 to 80 percent water. Dewatering the concentrate in a thickener, then in disc or drum filters for final dewatering, produces a relatively dry product ready for further shipping and processing.

The collected water is usually recycled to the milling circuit. The settling of solids in the thickeners is enhanced by chemical reagents known as flocculants. Filter cake moisture is regulated by reagents known as filtering agents. Typical flocculants and filtering agents used are polymers, nonionic surfactants, polyacrylate, and anionic and nonionic polyacrylamides. At most facilities, thickening of tailings is a common step prior to pumping the thickened slurry to the tailings pond and ultimately disposing of the thickened slurry. Thickening minimizes the amount of water placed in the pond and the pond size.

Thickening is usually accomplished by settling in large tanks, known as thickeners. The settling of solids in tailings thickeners is also enhanced with flocculants. Gravity causes the flocculated solids to settle to the bottom of the thickener, where they are scraped to a discharge outlet by a slowly rotating rake. Collected water from this process is generally recycled back to the mill to be used in beneficiation activities.

7.3. HYDROMETALLURGY

7.3.1. LEACH OPERATIONS (IN SITU, DUMP, HEAP AND VAT)

Copper is increasingly recovered by solution, or hydrometallurgical, methods. These include dump, heap, and vat leaching techniques, as well as underground (or in situ) leaching methods. Each of these methods results in a pregnant leach solution (PLS). Copper is recovered from the PLS through precipitation or by solvent extraction/electrowinning (SX/EW).

Most ores occur as mineral compounds that are insoluble in water; leaching involves chemical reactions that convert copper into a water-soluble form followed by dissolution. The leaching reagent used by each operation is dependent on the mineralogical composition of the ore material. Several types of reagents are used to produce these chemical reactions, including acids and bacterium.

Acid leaching of ores and concentrates is the most common method of hydrometallurgical extraction. Its use is confined to acid-soluble, oxide-type ores that are not associated with acid-consuming rock types containing high concentrations of calcite (such as limestone and dolomite). Some ores require a form of concentration and/or pretreatment, such as roasting or calcification, before leaching.

Typical acidic leaching agents include hydrochloric acid (HCL), sulfuric acid (H₂SO₄), and iron sulfate (Fe₂(SO₄)). Sulfuric and hydrochloric acid leaching at atmospheric pressure is the most common type of copper leaching. Copper minerals such as azurite, malachite, tenorite, and chrysocolla, are completely soluble in sulfuric acid at room temperature.

Other, less oxidized, cuprite and sulfide ores, such as chalcocite, bornite, covelite, and chalcopyrite, require the addition of ferric sulfate and oxygen (as oxidants) to accomplish leaching. Leaching ores containing bornite and chalcopyrite with ferric sulfate is very slow, even at elevated temperatures. For certain minerals, alkaline (or basic) leaching is an effective means of extracting copper. Alkaline leaching is more selective than acid leaching and particularly appropriate for ores with large amounts of acid consuming carbonate rocks. This selectivity often results in lower recovery if the metals are not fully liberated in the comminution stage. Silica- and silicate-rich ores can be treated using alkaline leaching agents at raised temperatures.

The principal reagents used in alkaline leaching are the hydroxides and carbonates of sodium and ammonia, but potassium hydroxide, calcium hydroxide, and sodium sulfide also are used. When leaching with ammonia (NH₃), ammonium carbonate

[$\text{NH}_3/(\text{NH}_4)_2\text{CO}_3$] or ammonium sulfate ($(\text{NH}_3)_2\text{SO}_4$) systems are often used. Those metals, which can form amines of copper, cobalt, and nickel, can be dissolved in ammoniacal ammonium carbonate or ammoniacal ammonium sulfate solutions at atmospheric pressure. Native copper can be leached in hydrochloric acid or by ammonia/ammoniacal ammonium sulfate agents.

Microbial (or bacterial) leaching is appropriate for low-grade sulfide ores at dump, and heap leach, underground or possibly in situ leaching operations. This type of leaching is much slower than typical acid or basic leaching. The organism involved in bacterial leaching is called *Thiobacillus ferrooxidans*, a small rodshaped cell about 1 micron for cell growth and oxidizes ferrous iron and sulfides to obtain energy for growth. Sulfuric acid is a product of the organism's metabolism. Sufficient dissolved oxygen must be available during these oxidation reactions. The other main growth requirements are ammonia, nitrogen, phosphate, and a suitable temperature approximately 30 and acidity (approximate pH of 2.0). In general, higher or lower temperatures lower acidities (pH of 0.5 or 4.5) will not kill the organism, but will severely curtail its activity. *Thiobacillus ferrooxidans* is usually present in a natural, acidic, sulfide environment. Some metals, such as mercury, silver, and (possibly) molybdenum, can retard or stop leaching by inhibiting or killing the bacteria. Bright sunlight or shallow ponds containing certain other bacteria can also inhibit their activity. The chemical and biochemical reactions involved in microbial leaching of copper ore/minerals are complex.

For chalcopyrite, a copper sulfide, it appears that bacteria must come into contact with the mineral to "catalyze" the oxidation reaction. The bacteria first oxidizes the ferrous ore to ferric iron. Ferric iron then chemically oxidizes the sulfide. This bacteria can also assist in the oxidation of sulfur to sulfuric acid. The same reaction also may proceed in the absence of the bacteria, but at a much slower rate. A similar type of reaction occurs for the oxidation of pyrite. These reactions dissolve the sulfide minerals and produce an acidic copper sulfate solution containing ferrous and ferric iron. Other copper sulfide minerals, such as chalcocite, digenite, bornite, and covellite, are more easily leached than chalcopyrite.

In some cases, the amount of copper released during the leaching of low-grade sulfide ores has been found to be directly proportional to the quantity of oxygen reacting with the ore. The rate of oxidation depends on a variety of factors; however, the rate can be maximized by maintaining a relatively low pH; the lower the pH, the faster the rate

of oxidation. At pH levels above 2.5 or 2.6, the leaching of copper appears to slow considerably.

Leaching with cyanide has been applied almost exclusively to gold and silver, but cyanide has been applied also to copper for both oxidized and low-grade sulfide ores. The effectiveness of cyanide in leaching depends on the ability of the cyanide ion to form stable complexes with the majority of transition metals. These complexes are strong enough to overcome the relative inertness of gold and silver and the insolubility of copper minerals, such as chalcocite, to form copper-cyanide complexes [CuCN, $\text{Cu}(\text{CN})_2^-$, $\text{Cu}_2(\text{CN})_3^-$, and $\text{Cu}(\text{CM})_3^{2-}$]

In these techniques, copper values are extracted in aqueous solutions from ore or concentrates. The metal and byproducts are then recovered from the PLS by chemical and electrolytic methods.

In Situ Leaching

Another leaching method, involving the leaching of low-grade copper ore without its removal from the ground, is known as in situ leaching. In situ leaching generally refers to the leaching of either disturbed or undisturbed ore.

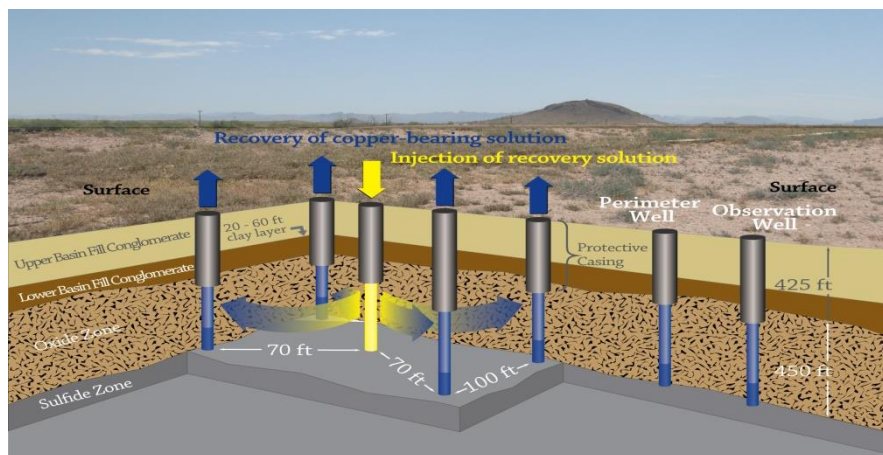

Figure 54. In Situ Leaching

Source: cim.org

In either case, in situ leaching allows only limited control of the solution compared to a lined heap leach type operation. In situ leaching has certain advantages over conventional mining and milling, including lower capital investment, lower operating costs, and faster startup times. In situ leaching of undisturbed ores is best suited for mining relatively deep-lying oxidized copper deposits. In situ leaching of disturbed (rubblized) ore is used for extracting copper from any porous or permeable deposits.

In situ leaching of undisturbed ore, where the rock has not been moved from its pre-mining position, involves very different mining technologies from deposits that have been fragmented by mining operations (such as backfilled stope, and previous block-caving mining operations) or hydrofractured areas, extracts copper from subsurface ore deposits without excavation. Typically, the interstitial porosity and permeability of the rock are important factors in the circulation system. The solutions are injected in wells and recovered by a nearby pump/production-well system. In some cases (where the ore body's interstitial porosity is low), the ore may be prepared for leaching (i.e., broken up) by blasting or hydraulic fracturing.

The chemistry of in situ leaching is similar to that of heap and dump leaching operations. The ore is oxidized by lixiviant solutions such as mine water, sulfuric acids, or alkalines that are injected from wells into an ore body to leach and remove the valuable minerals. Production wells capture and pump pregnant lixiviant solution from the formation to the leach plant where copper metal is recovered by an SX/EW operation.

Monitoring wells are used to monitor the ground-water system and detect any lixiviant migration beyond the leaching area. After the ore body is depleted, in situ leach operators may be required to restore the aquifer.

In situ mining of undisturbed ore is being conducted on an experimental basis in the copper mining industry.

The economics of current mining and recovery methods often prevent the mining of ore that either contains insufficient metal values or requires extensive site preparation or operating expense.

For this reason, the in situ leach method is gaining favor as a means of recovering additional copper from old mine workings (i.e., block-caved areas and backfilled stopes) from which the primary sulfide deposit has been mined. These types of operations tend to leave behind considerable fractured, copper-bearing rock that is expensive to mine and recover by conventional means.

Stope leaching is a specialized type of in situ solution mining that involves leaching of underground, low grade ore deposits at active and inactive mines. Lixiviant solution is introduced into a worked-out underground mine; backfilled underground stopes; or collapsed block-caved areas (where the stopes were backfilled with low-grade waste rock). As the fluid flows through the stopes or caved areas, it dissolves the minerals

and collects in lower levels of the mine (i.e., the sumps); from there it is pumped to the surface.

There, the copper is recovered by the SX/EW method. One example of stope leaching occurs at Magma Copper Company's San Manuel facility, where in situ leaching, open pit mining, and underground mining are all conducted simultaneously in different parts of the same ore body. During the last few years, all of the production from Cyprus' Casa Grande property has been from in situ leaching, including a stope leaching project and testing of in situ leaching of virgin ground.

Most abandoned underground mining operations leave halos or zones of low-grade ore surrounding tunnels, stopes, rises, and pillars. The underground mine development (i.e., the shafts and drifts) required in such mines normally provides the basic circulation needed for a leaching operation. Usually, lixiviant solutions are introduced into the surrounding low-grade ore zones from above by injection through a series of drillholes. The main shaft is almost always used as a main drainage reservoir. Because drifts are designed to run upgrade, water or leach solutions flow naturally by gravity to the main shaft for recovery. Fluids flowing from the extraction drifts and haulage drifts are usually collected behind a dam placed across the main shaft and pumped to the surface. At block-caved operations, the caving method causes the area above the stope mine to be highly fractured and broken. This expands its volume, which increases the porosity of the low-grade ore. Thus, an ideal circulation system for stope leaching operations is created.

Dump Leach Operations (At Open-Pit Mines)

Dump leaching refers to leaching that takes place on an unlined surface. The term "dump leaching" derives from the practice of leaching materials that were initially deposited as waste rock; however, now it also is applied to of run-of-mine, low-grade sulfide or mixed grade sulfide and oxide rock placed on unprepared ground specifically for leaching.

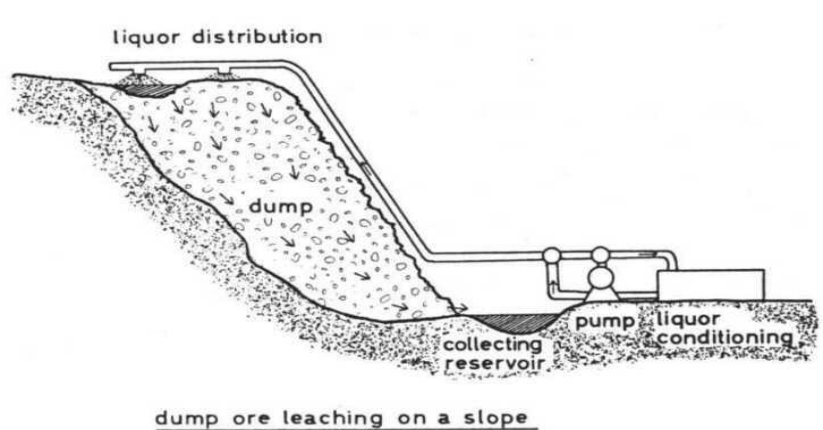

Figure 55. Dump Leaching
 Source: spaceship-earth.de

Copper dump leaches are typically massive, with waste rock piled into large piles ranging in size from 20 feet to over 100 feet in height. These may cover hundreds of acres and contain millions of tons of waste rock and low-grade ore.

In the 1920s, large-scale commercial leaching of waste piles was initiated to recover copper. These operations entailed the addition of low pH solution to the piles to accelerate leaching, the collection of PLS, and the extraction of copper by iron precipitation to generate "cement copper." The sites for these historic dump leaches were selected primarily to minimize haulage distances, thereby reducing costs (the extent of cost savings would have been based on site specific factors). Dump leaches were located and designed to prevent the loss of leach solution.

Waste rock, removed to expose the ore body, was placed in piles close to the pit site. Water seepage from the piles was found to contain high concentrations of copper. Miners realized the opportunity to recover copper at virtually no cost. The percentage of copper produced from leaching operations has increased in recent years due to the low operating costs of dump leaching relative to conventional milling operations (the extent of cost savings is based on site-specific factors).

Dump leaching is usually associated with copper recovery, although uranium and gold may be leached through a similar procedure. Dumps are usually sited in an area where the slope of the native terrain provides the means for collection of pregnant liquor. The leach solution flows by gravity through the dump and then over the slope of the native ground beneath the dump to a collection point, usually a pond, at the downgrade toe of the dump.

The materials employed generally vary considerably in particle size, from large angular blocks of hard rock to highly weathered fine-grained soils. Most of the material is less than 0.6 meter in diameter. In most dump leach operations, the material is hauled to the top of the dump by trucks. Bulldozers are used to level the surfaces and edges of the dump. The material is typically deposited by end-dumping in lifts on top of an existing dump that has already been leached. Large dumps are usually raised in lifts of 15 to 30 meters.

Some sorting of materials occurs when this method of deposition is used. Coarser fragments tend to roll down to the bottom of the slope, whereas finer materials accumulate near the surface of the dump. A degree of compacting in the top meter of each lift results from the heavy equipment and truck use. After the lift is completed, the top layer is scarified (by a bulldozer and a ripper) to facilitate infiltration of the leach solution.

Most dump leaches begin to settle as they are built and continue to settle after the leach solutions have been applied. This continued settling results, in part, from the percolating liquid moving the finer particles into the spaces between larger particles. The dump is compressed also by the added weight of the solutions and the destruction of the bridging rocks' competency by chemical reactions that depreciate the rock.

Natural precipitation, mine water, raffinate, makeup water, or dilute sulfuric acid may be used as leach solution (i.e., lixiviant). As the lixiviant infiltrates the pile and leaches out copper minerals by oxidizing the pyrite to form sulfuric acid and ferrous iron solution, the sulfuric acid solution reacts with the ore minerals to ionize the copper into solution. Once dissolved, the metals remain in solution. This leaching method is best suited to nonsulfide oxide ores rich in azurite, malachite, and other oxide minerals. Sulfide ores rich in chalcocite may also be leached using a similar method. In this method, the ore is leached by an active bacterial population that uses oxygen to convert ferrous iron to ferric iron, which reacts with chalcocite liberating copper and generates ferric sulfide.

Several methods may be used to distribute leach solutions over the dumps, including natural precipitation, sprinkler systems that spray the leach solution over the piles, flooding of infiltration ditches or construction of leach solution ponds on top of the dumps, distribution of leach solution through perforated pipe on top of the dump (known as trickle systems), and the injection of leach solutions through drill holes into

the dump. The leach solution percolates through the dump and PLS is collected in ditches or sumps at the toe of the dump.

These ditches and sumps are lined at some sites, and are unlined at others. PLS is then treated by solvent extraction or cementation. Metals associated with the copper ores that dissolve (and are potential contaminants) include arsenic, cadmium, chromium, and selenium.

Heap Leaching

In contrast to dump leaching, heap leaching refers to the leaching of low grade ore that has been deposited on a specially prepared, lined pad constructed using synthetic material, asphalt, or compacted clay. In heap leaching, the ore is frequently beneficiated by some type of size reduction (usually crushing) prior to placement on the pad. Site-specific characteristics determine the nature and extent of the crushing and the leaching operations used.

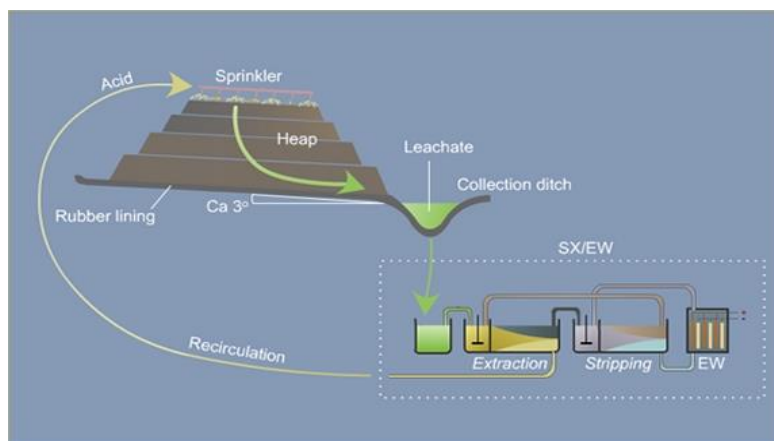

Figure 56. Heap Leaching

Source: technology.infomine.com

Heap leach pads are constructed above one or more layers of impermeable liner material. Liners can be constructed using synthetic membrane [such as High-Density Polyethylene (HDPE)] and/or natural material (such as compacted native soils or clays or unfractured/unfaulted bedrock). Most leach sites are selected to take advantage of existing, less permeable surfaces and to utilize the natural slope of ridges and valleys for the collection of PLS. Land with this type of geology and terrain, however, is not always within a reasonable hauling distance of the mining operation.

The same basic principles and procedures discussed earlier with regard to dump leaching operations apply to heap leach operations. Heap leach operations, as opposed to dump leach operations, have the following characteristics:

- (1) higher lixiviant concentrations generally are used;
- (2) leach piles may be neutralized after leaching operations are completed;
- (3) the leach pad design is substantially different (i.e., the size is smaller);
- (4) the ore is finer grained (i.e., usually less than 10 cm);
- (5) the leaching is considerably faster; and (6) the extraction of oxide copper is greater.

The copper recovery of sulfide minerals in the heaps, as with dumps, is usually low due to shorter leaching times (100 to 180 days) and relatively poor lixiviant-sulfide dissolution kinetics.

Heap leaching is generally suited to oxide ores for several reasons: usually oxide deposits are smaller than sulfide deposits; oxides leach more rapidly than sulfides; the oxide leachate has a higher copper content than the sulfide leachate; and high-grade refractory oxide ores are not recoverable in the standard sulfide flotation concentrator. Copper heap leach operations are much smaller than copper dump leaches.

On the average, heaps contain between 100,000 and 500,000 metric tons of ore. Copper heaps are designed and operated to minimize truck traffic and bull-dozer work on the surface. This serves to reduce the compaction resulting from these activities, thereby improving the permeability of the heap. One method of constructing a new heap involves placement of the leach material in a strip along the center of the new heap.

Subsequent loads are then dumped along the outer edge of the strip and pushed over the side with a bulldozer to build the heap to its full width. With this method of material emplacement, only the top meter of the heap becomes compacted. This layer is subsequently scarified to promote infiltration of the leach solution. The heap leaching cycle typically lasts between 60 and 180 days. Application of leaching solution is generally stopped after a specified period, which is dictated by the leaching cycle or when the copper content of the pregnant liquor falls below a predetermined concentration. Subsequently, the surface of the nearly barren area is scarified by ripping and another lift is begun on the surface.

Because most distribution methods do not provide completely uniform coverage, the rate at which the solution is applied to the heap will vary. The application rate is

generally defined as the volumetric flow rate of the leach solution divided by the surface area to which the solution is actually being applied. The average application rate varies between 20 liters per square meter (l/m^2) per hour for sprinklers, to as much as 200 l/m^2 per hour for pond leaching.

In practice, most heaps are leached in sections. Near the end of the leach cycle, heap permeability diminishes because of the accumulation of decomposed clay materials and iron salt precipitates. This requires that the surface be scarified by ripping, after which leaching is resumed or another lift is begun on the surface. The alternate wetting and resting during the leach cycle promotes efficient leaching of sulfide minerals within the heap.

Vat and agitation (tank) leaching are usually performed on relatively higher oxidized ores. Tank methods tend to recover copper more rapidly using shorter leach cycle times than heap or dump leaching operations.

Generally, copper recovery is higher, copper content in the leach solution is higher, and solution losses are lower with tank methods. Vat leaching has been preferred over heap leaching in cases where high-grade ore requires crushing to permit adequate contact between the leach solution and the copper minerals. The advantages of this method are high copper extraction rates and recoveries, short leach cycles, and negligible solution losses. The disadvantages are the low tonnages beneficiated, high suspended solids concentrations in PLS that cause problems in the SX/EW plant, and high operating costs.

In the tank leaching process, the ore is first crushed to approximately less than 1 cm. The ore is screened to separate the fines before it is placed in the vats. Most vat leaching operations use several large, rectangular tanks with floors that act as filters to facilitate the up flow and down flow of solutions. A typical vat measures 25 meters long, 15 meters wide, and 6 meters deep and contains between 3,000 and 5,000 metric tons of material. Vat leaching is a batch operation; its cycle involves vat loading; ore leaching, washing, and draining; and vat excavating. The crushed ore is immersed in 50 to 100 kilograms per cubic meter (kg/m^3) of sulfuric acid solution. The leaching usually takes place in a sequence of four to seven soak-drain cycles. The pregnant solutions from the first two or three soaks are used as electrolyte (after purification), while the remaining solutions (which are more dilute) are reused to leach subsequent fresh batches of ore. The solutions from the remaining soaks are recycled as leachate for subsequent batches of fresh ore.

Continuous vat leaching, in which leachate flows continuously through ore in a sequence of vats, is now being practiced at several mines. Factors that affect the leach rate (in both batch and continuous leaching) include particle size and porosity, temperature, and acid strength. The overall cycle may take from 10 to 14 days. Vat leaching produces a PLS of sufficient copper concentration for electrowinning (30 to 50 kg/m³ of copper). If the iron content of the solution is high, the PLS may be sent for solvent extraction prior to electrowinning. This is necessary because iron may reduce the efficiency of the electrowinning.

Agitated vat leaching refers to the relatively rapid leaching of fine particles of copper oxide ore or roaster calcines with a strong sulfuric acid solution in agitated tanks. The tanks are stirred or agitated by mechanical devices or piped steam discharge. Compressed air is used in a similar method of agitation in a pressurized tank operation. This leaching method has been used primarily in conjunction with vat leaching operations to recover copper from the fines filtered out of the vat material. Additional lean material is crushed and ground to a fine-sized particle [90 percent are less than 75 micrometers (μm)] and combined with the fines from the vat operation.

This material is then mixed with the leach solution to form a slurry with a solids content of between 30 and 40 percent. The mixture is agitated by air or mechanical means in a series of three or six tanks [with a volume of 50 to 200 cubic meters (m³)] for a period of two to five hours. On completion of the leach cycle, the pregnant liquor is separated from the acid-insoluble residue by concurrent or countercurrent washing.

Because of the fine particle size of the solids, the strength of the acid solution, and the agitation of the leach slurry (which promotes better liquid-solid contact), agitation leaching demonstrates the highest recovery of copper. In some instances, recovery is greater than 95 percent. Vat and agitation leaching are generally more rapid, more efficient, and much more costly than dump or heap leaching.

Cementation

In the past, copper was recovered from leach solutions through a cementation technique (precipitation from solution by the replacement of copper in solution by metallic iron). This has been a source of relatively inexpensive copper; however, the cement copper produced is relatively impure compared to electrowon copper and must be smelted and refined along with flotation concentrates.

In the cementation technique, PLS flows to a precipitator pond filled with scrap iron or steel.

The copper chemically reacts with, and precipitates onto the steel surfaces. The iron is dissolved into solution, and the copper precipitates out (i.e., replaces) the iron. The cemented copper later detaches from the steel surfaces as flakes or powder when it is washed with high-pressure streams of water. Although subsequent treatment by a normal smelting/refining method is required, copper recovery from the pregnant solution is very high.

Typically, cemented copper contains between 65 and 85 percent pure copper, with oxides of iron and other traces of silica and aluminum oxides.

Swapping ions occurs whenever a metal ion in solution is reduced to an elemental state by a more reactive metal. Iron is more reactive than gold, mercury, silver, or copper; hence these metals easily precipitate. Iron is only slightly more reactive than lead, tin, nickel, or cadmium; and these metals do not easily precipitate since kinetics control the reaction. Chromium, zinc, aluminum, magnesium, calcium, and sodium are more reactive than iron and also do not precipitate. As a result, barren leach solutions remain very acidic and contain elevated levels of metals and salts that are more reactive than iron or are similarly reactive.

There are numerous cementation precipitator designs and configurations. Typically, precipitators are shallow-round or stair-stepped wooden or concrete basins.

The simplest and most common precipitation system used in the copper mining industry is an openlaunder-type cementation system. PLS flows down a wooden or concrete trough or series of troughs filled with scrap iron. Launderers vary in size and dimension depending on the amounts of leach liquor being treated; the launder may be straight or zigzagged. More modern units employ a series of wooden grids, positioned above the bottom of the launderers. These permit the cemented copper to fall to the bottom, where it easily can be recovered.

Several compact and dynamic cementation systems have been developed and are used industrially. The most successful is the Kennecott Cone System Precipitator, in which the PLS is forced upwards in a swirling motion through shredded steel scrap. Consequently, the cement concentrates containing the pulp must be further beneficiated by flotation. The cemented copper is easily floated with xanthate or dixanthogen collectors.

Ion Exchange

The use of ion-exchange recovery in the copper industry is not widespread. Generally, three circuits are used in an ion-recovery operation: the extraction circuit, the elution circuit, and the precipitation circuit. The system is designed to recycle lixiviant back to the leach operation.

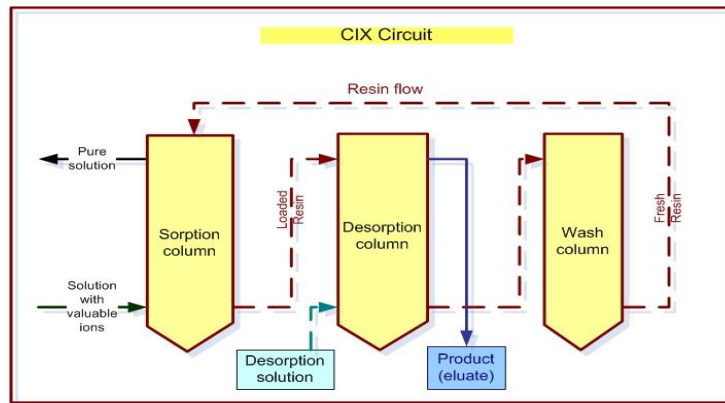

Figure 57. Ion exchange

Source: ion-exchange.com.au

The extraction circuit extracts metals from the pregnant lixiviant. Copper complexes with the resin as the pregnant lixiviant flows through the resin in the ion exchange unit. Barren lixiviant leaving the ion exchange unit is refortified with chemicals and recycled. The copper metal is released from the loaded resin in the elution circuit. This is accomplished using a high-ionic-strength solution. The effluent is known as the pregnant eluate. The pregnant eluate proceeds to the precipitation circuit, where acid is added to destroy the copper complexes in solution and precipitate copper oxide. The barren electrolyte is reprocessed to the elution circuit, although electrolyte is constantly bled from the system to control the level of impurities.

Solvent Extraction

The first SX/EW plant was developed during the 1960s at the Bluebird property near Miami, Arizona. Solvent extraction largely had been confined to copper oxides until recent developments in leaching methods.

In the traditional solvent extraction circuit, copper is dissolved from the ore into an aqueous solution by weak sulfuric acid. The pregnant solution is then pumped to a solvent extraction plant, where it is mixed with an organic solvent.

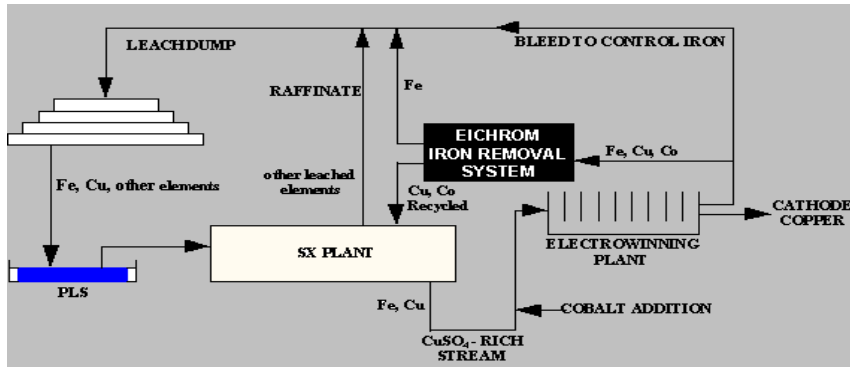

Figure 58. SX/EW Process
Source: eichrom.com

The solvent extraction operation is a two-stage method. In the first stage, low-grade, impure leach solutions containing copper, iron, and other base-metal ions are fed to the extraction stage mixer-settler. In the mixer, the aqueous solution is contacted with an active organic extractant (chelating agent) in an organic diluent (usually kerosene), forming a copper-organic complex. The organic phase extractant is designed to extract only the desired metal ion (i.e., copper), while impurities such as iron or molybdenum are left behind in the aqueous phase. The aqueous-organic dispersion is physically separated in a settler stage.

Because of the development of the faster, more selective salicylaldoxime reagents, most of the new copper solvent extraction plants can use two-stage extraction with a single stripping stage in each circuit. Two stages of extraction have proven sufficient to remove 90 percent or more of the copper from leach solutions, whereas early plant designs required three or four stages of extraction.

The barren aqueous solution, called raffinate, is recirculated back to the leaching units. The loaded organic solution is transferred from the extraction section to the stripping section. The major advantage of solvent extraction is that the electrolyte solution it produces is almost free of impurities.

In the second stage, the loaded organic solution is stripped with concentrated sulfuric acid solution (spent tankhouse electrolyte) to produce a clean, high-grade solution of copper for electrowinning. The stripping section can have one or more mixer-settler stages. In particular, the loaded-organic phase is mixed with a highly acidic electrolyte (returned from electrowinning), which strips the copper ions from the organic phase. Then the mixture is allowed to separate in settling tanks, where the barren organic solution can be recycled to the extraction stage. The copper-enriched, strong

electrolyte flows from the stripping stages to the strong electrolyte tanks, where it is pumped to the electrolyte filters for removal of the entrained organics or solids.

The clarified, strong electrolyte (which is the concentrated sulfuric acid from the solvent extraction operation) flows to electrolyte circulation tanks, where it becomes electrolyte for the electrowinning tank house. At the tank house, copper is plated out of solution onto cathodes.

The solvent extraction method is dependent on the solubility of the reagents and the equilibrium constants that control the reactions. The higher the equilibrium constant, the more effective the reagent is in stripping copper from the pregnant solution. Specifically, two factors that are controlled by the equilibrium constant and that significantly impact the effectiveness of a reagent are the rate of the reaction and the range between loading and stripping for a particular reagent.

The most prominent copper extractants used in the copper plant solvent extraction system are LIX and Acorga. These reagents are referred to by their individual trade names because their exact chemical compositions are listed as confidential business information (although some general information is available).

Modifiers are usually added to improve the reaction rates and/or phase separation. Data are very limited on the various types of modifiers used at copper extraction plants, although several were identified: LIX 6022 is a tridecanol-modified dodecylsalicylaldoxime; PT-5050 is a tridecanol-modified nonylsalicylaldoxime; LIX 860 is an unmodified dececylsalicylaldoxime; LIX 84 is an unmodified nonylacetophenone; and LIX 984 is 50-50 mixture of LIX 860 and LIX84.

The obvious advantage of solvent extraction is that cathode copper of salable quality can be produced directly from leach solutions. Therefore, smelting is not required. Interest in the SX/EW method has grown gradually. Twelve plants were in operation during 1989. Several expansions and new plants are being planned, while the cementation process is being phased out (except as a subsidiary method of copper production).

Electrowinning

Electrowinning is the method used to recover copper from the electrolyte solution produced by solvent extraction. Electrowinning uses inert (nondissolving) anodes made of lead (alloyed with calcium and tin) or stainless steel, referred to as sheets.



Figure 59. Electrowinning Process

Source: outotec.com

To stabilize the tank house operating temperature and preheat the incoming electrolyte solution, strong electrolyte (after filtration) is passed through heat exchangers where heat is extracted from outgoing, warmer, spent electrolyte. After passing through starting-sheet cells, the strong electrolyte is received in a circulation tank.

In the circulation tank, the strong electrolyte is mixed with spent electrolyte returning from the electrowinning cells. Water and any deposit-modifying reagents are added in this tank. The feed electrolyte is then pumped to the electrolytic cells continuously. The electrochemical reaction at the lead-based anodes produces oxygen gas and sulfuric acid by electrolysis. Copper is plated on cathodes of stainless steel or on thin-copper starting sheets. The cathode copper is then shipped to a rod mill for fabrication. The spent acid is recycled and pumped back to the leaching operation, while some of the electrolyte is pumped to the solvent extraction strip-mixer-settlers via the electrolyte heat exchangers.

If the cathode copper is plated onto a stainless steel "blank," the copper plate is peeled off the blank prior to shipment and the blank is reused. This blank and the techniques developed to optimize its use are known as the "ISA" method. Magma Copper Co. has

extended the use of this technology, which was first used in electroplating, to electrowinning operations.

The ISA method uses conventional, insoluble anodes, but rather than using starting sheets to receive the cathode deposit, the ISA method employs 316L stainless steel blanks. About 7 days are required to complete a cathode side, and automated equipment is used to strip them. This total production stripping system has numerous benefits, including the following:

- There is no starting-sheet deposition.
- There is no stripping labor, stripping, or sheet-fabrication equipment.
- The better-defined cathode (in the form of a rigid blank) is less prone to warping, and therefore, requires less rigid inspection.
- Shorter cathode cycles reduce the metal inventory.
- There are no suspension loops to corrode. Therefore, the incidence of cell-liner cutting is lower and crane handling is easier.

The elimination of sheet production and reduced inspection means the work force is up to 60 percent smaller than it is at a conventional plant. [13]

7.4. PYROMETALLURGY EXTRACTION

There are two stages in pyrometallurgical extraction

- I. smelting of concentrates to matte
- II. converting matte by oxidation to crude (converter or blister) copper

Refining the crude copper, usually is done in two steps

- I. pyrometallurgically to fire-refined copper
- II. electrolytically to high-purity electrolytic copper

The large blast and reverberatory furnaces of the 1900s were derived from these principles. Later, the electric furnace for matte smelting was developed.

Newer processes are the Isasmelt/Ausmelt/Csiromelt (furnace with vertical blowing lance), the Noranda and CMT/Teniente reactors (developed from converters), the Russian Vanyukov, and the Chinese Bayia process.

7.4.1. BLAST FURNACE SMELTING

The blast or shaft furnace is well-suited for smelting high-grade, lumpy copper ore. If only fine concentrates are available, they must first be agglomerated by briquetting, pelletizing, or sintering. Because of this additional step and its overall low efficiency, the blast furnace lost its importance for primary copper production and is currently

used in only a few places, for example, Glogow in Poland. Smaller types of blast furnace, however, are used to process such copper-containing materials as intermediate products (e.g., cement copper or copper oxide precipitates), reverts (e.g., converter slag, refining slag, or flue dusts), and copper-alloy scrap. The construction of the furnace is basically related to that of the iron blast furnace, but there are considerable differences in design, especially in size and shape: the copper blast furnace is lower and smaller, and its cross section is rectangular. Developments adopted from the steel industry include use of preheated air (hot blast), oxygen-enriched air, and injection of liquid fuels.



Figure 60. Blast Furnace for Copper Smelting

Source:

The furnace is charged with alternate additions of mixture (copper-containing materials and accessory fluxes such as silica, limestone, and dolomite) and coke (which serves as both fuel and reducing agent).

There are three zones in the furnace:

- In the heating zone (the uppermost), water evaporates and less stable substances dissociate.
- In the reduction zone, heterogeneous reactions between gases and the solid charge take place.
- In the smelting zone, liquid phases react.

The usual mode of operation is reducing smelting, which yields two main products. Sulfide ores are used to produce a matte (40 – 50 wt % Cu) and a disposal slag (ca. 0.5 wt % Cu). In contrast, oxide ores are processed directly to impure black copper (95 wt % Cu) and to a copper-rich slag. The two ore types can be smelted together to produce matte and a slag with low copper content. Another product is top gas, which contains flue dust. Ores that contain high concentrations of arsenic and antimony also form speiss, which is difficult to decompose.

In Poland (KGHM Polska Meidz S.A. Smelters in Glogow I and Legnica) the blast-furnace technology is well adapted to Polish copper concentrates, which contain about 20 – 30 % Cu like normal chalcopyrites but also 5 – 10 % of organic carbon and only 9 – 12 % S. Also these concentrates have relatively high lead (up to 2.5 %) and arsenic (up to 0.3 %) content. The organic carbon compounds provide about 40 – 60 % of the process energy; the rest is added by coke. The matte has about 58 – 63 % Cu and 3 – 6 % Pb. The slag contains less than 0.5 % Cu.

The off-gas from the blast furnaces (three in each plant) is mixed with the converter gases (Hoboken Converter). It contains 7 – 10 % SO₂ and is sent to sulfuric acid production. The production figures are 80 000 t/a converter copper in Legnica, and 200 000 t/a in Glogow Smelter.

7.4.2. REVERBERATORY FURNACE SMELTING

The reverberatory furnace dominated copper matte smelting for much of the 1900s, because it was a good process for smelting fine concentrate from flotation. It is a fossil fuel fired hearth furnace for smelting concentrate and producing copper matte. The reverbs began to decline in the 1970s with the adoption of environmentally and energetically superior processes like flash smelting. Probably the last one was erected in 1976 in Sarchemesh, Iran.

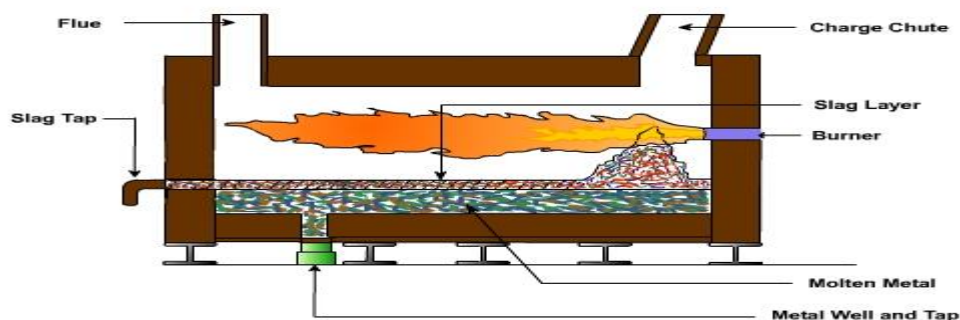

Figure 61. Reverberatory Furnace for Copper Smelting

Source: nptel.ac.in

In 1980 about 100 reverbs were in operation, but in 1994 the number had decreased to about 25. It is a rectangular furnace up to 10 m wide and 35 m long with internal brick lining. Throughputs of up to 1100 t/d concentrate or a mixture of concentrate and calcine could be processed. The charge is passed into the furnace near the burners through the roof or lateral openings.

As fossil fuel, pulverized coal, heavy oil, or natural gas is used. Normally the burner is located in the front wall of the furnace. The atmosphere is slightly oxidizing, and the maximum flame temperature is up to 1500 °C. During the 1980s oxygen – fuel burners have been set in the roof to fire downwards directly on the top of the bath. This increases the smelting rate by up to 40 % and the energy efficiency to about 50 %. Another invention was the sprinkler burner for feeding concentrate, coal, and flux from the top of the reverb.

Autogenous Smelting

Autogenous smelting involves the use of combustion heat generated by reactions of the feed in an oxidizing atmosphere in which the sulfide concentrate acts partly as a fuel. The formerly separate steps of roasting and smelting are combined into a roast – smelting process. The spatial and temporal coupling of exothermic and endothermic reactions leads to an economical process, but the sensible heat of nitrogen in the air causes a deficit in the heat balance.

In practice, various measures must be taken:

- Increasing the oxygen content of the combustion air and even using pure oxygen
- Preheating combustion air with waste heat or in a preheater
- Combustion of natural gas, fuel oil, or pulverized coal in supplementary burners

To achieve autogenous operation and prevent agglomeration of the feed, the moisture in the concentrate must be removed by drying before charging. The quantity of added fluxes is minimized as far as practical to save energy. Because the residence time of the sulfide particles in the reaction chamber is only a few seconds, kinetic conditions predominate over the thermodynamic equilibrium. The reactants form a heterogeneous system, with the feed suspended in the gas flow, thus the term smelting in suspension.

These processes have several advantages:

- High rate of reaction, increasing the production rate

- Energy savings
- Low volume of off-gas and correspondingly high concentration of SO₂ and low quantity of flue dust, if oxygen is used However, a typical disadvantage is the high copper content of the slags, and the relatively high flue dust content in the off-gas, which can cause problem in the waste-heat boiler.

7.4.3. FLASH FURNACE SMELTING

Outokumpu Flash Smelting after a preliminary test in 1946, the first full-scale flash smelting furnace started operation in 1949 at Outokumpu Oy, Harjavalta (Finland). Flash smelting has been the most widely adopted copper matte smelting process since 1970. More than 40 furnaces have been installed to replace reverberatory furnaces or at new smelting operations. Nowadays the Outokumpu-type smelters account for more than 50 % of world primary smelter capacity.

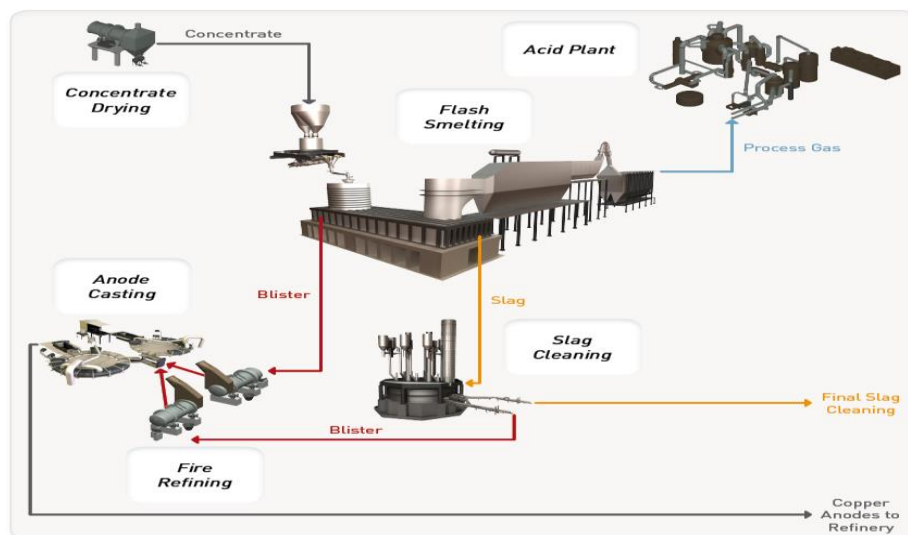

Figure 62. Flash Furnace for Copper Smelting

Source: outotec.com

7.5. CASTING

Normally molten metal from the furnace or holding section can be cast continuously or in batches. Continuous casting uses either vertical or horizontal modes but discontinuous casting normally uses the vertical mode. Upcast techniques are also used. Billets and cakes/slabs are produced and are processed further.

The normal shapes produced by casting are:

- Billets for the production of tubes, rods and sections using continuous or discontinuous casting
- Slabs or cakes for the production of sheets and strips using continuous or discontinuous casting

Metal is melted and passes via a holding furnace into a vertical or horizontal billet caster. Sections of billets are sawn off for further fabrication. Special processes are applied for specific products from copper and copper alloys: the upcast process for wires and tubes, horizontal continuous casting for strip and sections, vertical strip casting and roll process for the fabrication of copper tubes.

The cast strand on vertical or horizontal casting units is cut using the flying saw technique. In a discontinuous casting unit, the format length is determined by the depth of the casting pit. After reaching the maximum format length, casting is interrupted and the cast shapes are extracted by a crane or elevator. In the case of continuous casting, it is not necessary to interrupt the casting process. All casting operations need direct cooling water for final solidification and cooling down of the cast strand down to temperatures suitable for further handling. The cooling water can be recycled after sedimentation and the separation of solids (casting scales). If the scales are not contaminated with graphite or other particles, they are recirculated to a smelter for processing, if not directly reused in the casting shop.

7.6. FABRICATION OF TUBES, SECTIONS AND RODS

The fabrication process lines can be subdivided into two product groups, with each product group following the same process steps:

- Copper tubes in straight length and coils
- Copper (alloy) tubes, as well as copper and copper alloy rods, bars, wires and sections.

In both cases, the starting materials for the fabrication process are copper or copper alloy billets. The billets in a first stage are electrically or indirectly preheated by gas fired units and then pressed in unfinished tubes using hydraulically operated extrusion presses.

For the fabrication of copper tubes, depending of the type of product to be fabricated, different processes are industrially applied:

- Tube extrusion followed by multi step drawing to size
- Tube extrusion followed by breakdown rolling followed by several steps of drawing to size
- Hot piercing mill followed by breakdown rolling and drawing to size.
- ✓ For billets which are extruded or rolled into tubes with thick walls, breakdown rolling normally is the preference for the first size reduction step.
- ✓ For tubes extruded to thin walls, tube drawing machines are applied.
- ✓ For the fabrication of copper alloy rods, bars, wires and sections, the processes that are normally used are material extruding in coils or straight lengths followed by cleaning and pickling, drawing to size (using draw benches or continuous drawing machines), heat treatment for certain alloys, and straightening and sawing.

The whole process, starting with the extrusion press or the hot piercing mill, is a sequence of (mostly) reducing steps changing the shape and size. During these processing steps, the tools of the equipment for size and shape changing are cooled and protected by adequate media, using emulsion for the breakdown rolling and lubricants for the drawing units. The emulsions for the breakdown rolling are cleaned up by filtration, thus increasing the lifetime and reducing the amount of lubricant to be disposed of after treatment. However, the lubricants used for the drawing steps are completely lost with the product and no oily materials have to be rejected from the drawing processes.

The products are normally annealed and degreased before transport and the off cuts are deoiled in a furnace or other degreasing processes before being returned to the furnace for melting.

Products are annealed in a variety of furnaces under reducing conditions using (as the protection gas) exogas or hydrogen/nitrogen mixtures.

Copper tubes may also be produced utilizing an extrusion press with a piercer in which billet sections are extruded to tube shell pieces; the tube shell pieces are then rolled

in a breakdown roller and finally drawn to size in drawing blocks. The oil utilized (in small quantities) for the drawing operations is neutralized using in line degreasing/pickling systems often connected with the annealing section.

7.7. FABRICATION OF SHEETS AND STRIPS

Slabs and cakes from the casting shop are, in most cases, the starting material for the fabrication of sheets and strips. The key elements of the fabrication process for flat products are the hot and subsequent cold rolling operations. In detail, the fabrication process comprises the following steps:

- Preheating
- Hot rolling and milling
- Cold rolling
- Intermediate annealing
- Pickling, rinsing and drying
- Rerolling and strand annealing
- Finishing:
 - ✓ sheets (cutting to length)
 - ✓ strips (cutting to width).

The hot rolling of the cast slabs takes around 15 to 20 slabs until the final shape is reached, and is determined by the slab weight. There is no loss of metal during hot rolling so slab and coil weight are identical. The hot rolling mill does not require protection gas. The noise development during rolling is controlled by protective measures.

Hot rolling is usually done with a dual rolling mill equipped with benches up to 200 m and a final coiling device. The cooling water for the rolls has small amounts of lubricant added to improve the attachment to the steel rolls. The vapor generated is vented and the vent gas is demisted prior to release to atmosphere.

Further cold rolling operations are then performed. Cold rolling results in a hardened metal. In most cases, the coil is annealed prior to cold rolling. Annealing is done under reducing conditions to avoid oxidation. A protection gas of exogas or nitrogen/hydrogen mixtures is used. Exogas is produced on site from natural gas in a special reactor, which is indirectly fired.

Nitrogen and hydrogen are purchased and stored on site in special tanks. The N₂/H₂

Protection gas mixtures are produced from the storage tanks by mixing the components in the ratio required. For annealing before cold rolling, bell type furnaces are used with electric heating or indirectly fired by natural gas or fuel oil. Tower type furnaces are applied for intermediate annealing of pre rolled coils.

The sheet thickness is further reduced by stepwise cold rolling operations on different reversing mills. Rolling mill designs such as single stand mills which are combined with an in line multi stand rolling mill are also applied.

The choice of mill used depends on the thickness of the sheet and on the desired dimensions of the coil.

During cold rolling, an emulsion or oil is used for roll protection. Therefore, the roll stands are vented and the ventilation gases are cleaned by mechanical filters, wet electrostatic precipitators or scrubbing. The emulsion and the oil is cleaned from the metal and cracked oil particles are removed by paper or textile band filters. [14]

8. SHAPPING PROCESS

The pure metal produced in refineries or remelting plants is manufactured into semi-fabricated products. By working processes copper is usually treated initially by noncutting, shaping processes to obtain semi-finished products or “semis”.

These processes are subdivided into hot working, cold working and, if necessary, process annealing. Hot working means plastic forming above the recrystallization temperature.

8.1. EXTRUSION

8.1.1. DIRECT EXTRUSION

This is the standard extrusion method. Here, the block is loaded into the container where the platen forces it through the die installed in the backstop. At the end of extrusion, the remaining input stock is shorn off, and the next block loaded. This direct method can produce both solid and hollow sections as well as seamless pipes over a mandrel. This advantage of maximized productivity is, however, offset by the drawback that the press stroke must overcome not only the material's forming resistance, but also the friction between the block and the container wall. This method is therefore preferred for materials that extrude under light to medium forces.

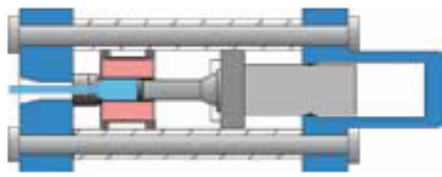

Figure 63. Direct Extrusion
Source: otto-fuchs.com

8.1.2. INDIRECT EXTRUSION

In the indirect extrusion the press forces the material block in the container against a hollow punch to which the die is attached. This method can produce both solid and hollow sections. The extruded section then flows through the hollow punch. Its measurements, however, are subjected to tighter limits than in direct extrusion. At the end of extrusion, the remaining input stock is shorn off. The next block can be clamped between the die and platen and introduced to the container. The advantage of this measure is that there is no friction between the block and container. The whole extrusion force is therefore available for forming the material. Hence, indirect extrusion is suitable for high resistance materials that deform only under particularly high forces.

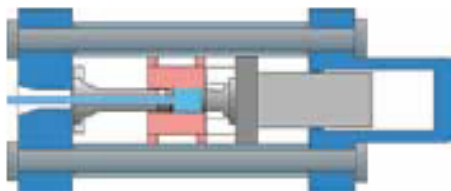

Figure 64. Indirect Extrusion
Source: otto-fuchs.com

8.1.3. EXTRUSION OVER A MANDREL

This method is used to manufacture seamless pipes and single-chamber hollow sections for applications that forbid moulding seams usual in porthole and composite dies. This is a variant of direct extrusion where a piercing mandrel in the platen first drives an initial hole through the material block loaded in the container. For the whole duration of extrusion, this piercing mandrel, whose geometry corresponds to the section's internal contours, remains in the die and with this provides the geometry for the required hollow section. [15]

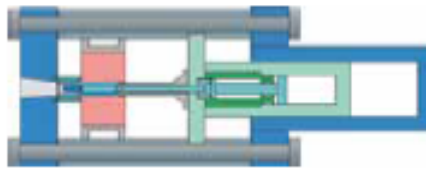

Figure 65. Extrusion with Mandrel

Source: otto-fuchs.com

8.2. DRAWING

Copper wire production includes production of round and profiled copper wire. These types of wire are produced by cold rolling and drawing process. Round and profiled wire is produced depending on tension strength value.

Wire is packed on the. Coils are wrapped by plastic foil and packed on wooden pallet. Each shipment is accompanied by quality certificate as guarantee of quality demands fulfillment. [16]

9. COPPER PRODUCTS

9.1. CONCENTRATE

Copper is extracted from underground or open pit mines, then crushed, ground into powder and processed into copper concentrate. Copper concentrate is the first product of the copper production line and is close to equal parts copper, iron and sulfide. Concentrates will have anywhere some percentage of copper depending on the region they are coming from. Most copper concentrate is sold directly to smelters and refineries. [17]

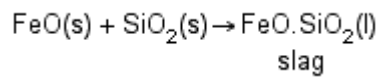

Figure 66. Copper Concentrate
Source: constructionphotography.com

9.2. MATT

The calcine is heated to over 1200 °C with fluxes such as silica and limestone. The calcine melts and reacts with the fluxes. Some impurities form a slag which floats on the surface of the liquid (like oil on water) and is easily removed.

For example:



This is very similar to the removal of impurities in the blast furnace. The liquid left is a mixture of copper sulfides and iron sulfides. It is called a matte.

9.3. BLISTER

The liquid matte is oxidized with air to form blister copper in a converter.

The reactions are:

a) Elimination of iron sulfide by oxidation to iron oxide which forms a slag:

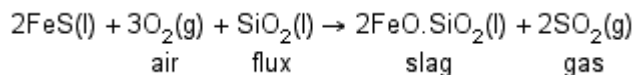

b) Formation of blister copper by reduction of copper sulfide:

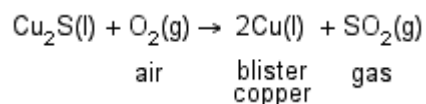

The blister copper produced by this process is 99% pure copper. The name 'blister' copper comes from the fact that this final process produces bubbles of sulfur dioxide on the surface of the copper. The blister copper is cast into anodes ready for electrolytic refining.

9.4. ANODE

The blister copper is already virtually pure (in excess of 99% copper). But for today's market, this is not really pure enough. It is purified further using electrolysis. This is known as electrolytic refining.

The blister copper is cast into large slabs which will be used as the anodes in the electrolysis apparatus. The electrolytic refining of copper produces the high quality, high purity copper required by industry.

In industry this is carried out on a massive scale. Even the best chemical method cannot remove all the impurities from the copper, but with electrolytic refining it is possible to produce 99.99% pure copper. The blister copper anodes are immersed in an electrolyte containing copper sulphate and sulphuric acid. Pure copper cathodes are arranged between the blister copper anodes and a current of over 200A passes through the solution. Under these conditions, copper atoms dissolve from the impure anode to form copper ions. These migrate towards the cathodes where they are deposited back as pure copper atoms.

At the anode: $\text{Cu(s)} \rightarrow \text{Cu}^{2+}(\text{aq}) + 2\text{e}^-$

9.5. CATHODE

Copper cathode is a form of copper that has a purity of 99.95%. In order to remove impurities from copper ore, it undergoes two processes, smelting and electrorefining. The resulting, nearly pure copper is an excellent conductor and is often used in electrical wiring. [18]

At the cathode: $\text{Cu}^{2+}(\text{aq}) + 2\text{e}^- \rightarrow \text{Cu(s)}$

9.6. SEMI FINNISHED AND FINNISHED PRODUCTS

9.6.1. RODS

Rods and sections made of copper and copper alloys are used for a number of components in power engineering such as terminals and commutators.

Especially sections are becoming ever more important to assure an economical production. In many cases, cutting the section to length is sufficient to make the required finished part.

The efficient use of sections leads to new, less expensive processing. Moreover, sections are particularly good due to a number of qualitative advantages, e.g. good strength properties through cold working all around the profile.

Sections are supplied in solid or hollow shapes. It is the material and geometry of the profile which largely determine whether a section can be made. Shape and dimensions are usually defined in a drawing. [19]

9.6.2. PIPE & TUBE

- Seamless Copper Pipe

Copper pipe is almost pure copper manufactured to the requirements of ASTM B 42 ,Standard Specification for Seamless Copper Pipe, Standard Sizes. It may be manufactured from any of five (5) copper alloys (C10200, C10300, C10800, C12000, C12200) that all conform to the chemical composition requirements of alloys containing a minimum of 99.9% Copper (Cu) and a maximum of 0.04% Phosphorous (P). Available sizes are 1/8" to 12" diameters in regular wall thickness and 1/8" to 10" in extra strong wall thickness. The standard length for copper pipe is 12 feet. Copper pipe is suitable for plumbing, boiler feed lines, refrigeration and for similar purposes. Joints in seamless copper pipe can be threaded, flanged or brazed to fittings of the appropriate joint configuration.

- Seamless Red Brass Pipe

(Red) Brass pipe is an alloy of copper manufactured to the requirements of ASTM B 43, Standard Specification for Seamless Red Brass Pipe, Standard Sizes. It is manufactured from alloy C23000 which is comprised of approximately 85% Copper

(Cu) with no greater than 0.05% Lead (Pb) and 0.05% Iron (Fe) and the remainder Zinc (Zn). Available sizes are 1/8" to 12" diameters in both regular and extra strong wall thickness. The standard length for red brass pipe is 12 feet.

Brass pipe is moderately resistant to many corrosive solutions and is often utilized for water supply and distribution. Joints in red brass pipe can be threaded, flanged or brazed to fittings of the appropriate joint configuration. Fittings in the smaller sizes, normally those below 2" diameter are, screwed cast copper alloy or brazed cup cast copper alloy. Fittings above 2" diameter are normally threaded, flanged, brazed or in some cases grooved mechanical joint fittings are employed.

- Seamless Copper Tube, Bright Annealed

Bright annealed copper tube is an almost pure copper tube manufactured to the requirements of ASTM B 68 - Standard Specification for Seamless Copper Tube, Bright Annealed. It may be manufactured from any one of the following alloys: C10200, C10300, C10800, C12000, or C12200 unless specified otherwise on the original contract or purchase order. ASTM B68 tube is suitable for use in refrigeration, fuel oil, gasoline, or oil lines where the interior surface of the tube is essentially free of any scale or dirt and is specifically specified as ASTM B68.

This tube is provided in annealed tempers meeting O50 - Light annealed or O60 - Soft annealed in either straight lengths or coils.

It is the responsibility of the purchaser, when ordering to provide the requirements for alloy (UNS#), temper, dimensions (diameter and wall thickness), form (straight lengths or coils), and total length or number of pieces of any particular size. It is this requirement that forces this tube to be a special order tube and not a standard stocked material. There is no specific requirements for identification of B68 tube and thus is not specifically designated as a tube permitted for use in most plumbing or mechanical codes. It is usually limited to use in specific manufacturing processes or production line type applications.

- Seamless Copper Tube

Seamless copper tube manufactured to the ASTM B 75, Standard Specification for Seamless Copper Tube may be either round, square, or rectangular and is suitable for general engineering applications. It may be manufactured from any one of the following alloys: C10100, C10200, C10300, C10800, C12000, or C12200 unless specified otherwise on the original contract or purchase order.

Tubes meeting this standard may be furnished in any of several tempers (H55, H58, H80, O60, or O50) ranging from light drawn (usually limited to round tubes) to light annealed. It is the responsibility of the purchaser, when ordering, to provide the requirements for alloy (UNS#), temper, dimensions (diameter, wall thickness, or distance between parallel surfaces), form (straight lengths or coils), and total length or number of pieces of any particular size. It is this requirement that forces this tube to be a special order tube and not a standard stocked material.

It is usually limited to use in specific manufacturing processes or production line type applications.

- Seamless Copper Water Tube

Copper water tube is a seamless, almost pure copper material manufactured to the requirements of ASTM B 88 - Standard Specification for Seamless Copper Water Tube, of three basic wall thickness dimensions designated as types K, L, and M. Type K is the thickest and type M is the thinnest with type L being of intermediate thickness. All three types of tube are manufactured from copper alloy C12200 having a chemical composition of a minimum of 99.9% Copper (Cu) and Silver (Ag) combined and a maximum allowable range of Phosphorous (P) of 0.015 %-0.040 %.

Seamless copper water tube is manufactured in sizes ¼" through 12" nominal. Types K and L are manufactured in drawn temper (hard) ¼" through 12" and annealed temper (soft) coils ¼" through 2" while type M is only manufactured in drawn (hard) temper ¼" through 12".

Seamless copper water tube of drawn temper is required to be identified with a color stripe that contains the manufacturer's name or trademark, type of tube and nation of origin. This color stripe is green for type K, blue for type L and red for type M. In addition to the color stripe the tube is incised with the type of tube and the manufacturer's name

or trademark at intervals not in excess of 1½ ft. Annealed (soft) coils or annealed straight lengths are not required to be identified with a color stripe.

- Seamless Brass Tube

Seamless brass tube is manufactured to the requirements of ASTM B 135 - Standard Specification for Seamless Brass Tube and may be either round, square, or rectangular and is suitable for general engineering applications. It may be manufactured from any one of the following alloys: C22000, C23000, C26000, C27000, C27200, C27400, C28000, C33000, C33200, C37000, or C44300 and these alloys contain Copper (Cu) concentrations of between 60% and 90% with various percentages of Zinc (Zn), Lead (Pb), and Tin (Sn) permitted, depending on the alloy.

Tubes meeting this standard may be furnished in any of several tempers ranging from light drawn to light annealed. It is the responsibility of the purchaser, when ordering to provide the requirements for alloy (UNS#), temper, dimensions (diameter and wall thickness, or distance between parallel surfaces), form (straight lengths or coils), and total length or number of pieces of any particular size.

- Wrought Seamless Copper & Copper Alloy Tube

ASTM B 251 - Standard Specification for General Requirements for Wrought Seamless Copper and Copper- Alloy Tube covers a number of general requirements common to many wrought copper products. A few of these specifications are B 68, B75, B135, B466 and B743. Products manufactured under the requirements of ASTM B251 may be of alloys of copper, brass or copper-nickel and may be produced in any number of tempers or shapes as specified by the purchaser.

- Air Conditioning & Refrigeration Tube

Copper tube used for air conditioning and refrigeration applications in the field (sometimes called "refer" or "ACR" tube) is an almost pure copper material meeting the requirements of ASTM B 280 - Standard Specification for Seamless Copper Tube for Air Conditioning and Refrigeration Field Service. It is manufactured from copper alloy C12200 having a chemical composition of a minimum of 99.9% Copper (Cu) and Silver (Ag) combined and a maximum allowable range of Phosphorous (P) of 0.015 % - 0.040 %.

B 280 tube is produced in straight lengths or coils in tempers H58 or O60 respectively, although annealed straight lengths may be special ordered. Straight lengths are provided in sizes from 3/8" O.D. through 4 1/8" O.D. while annealed coils are supplied in sizes ranging from 1/8" O.D. through 1 5/8" O.D. ACR tube is required to be identified in the following fashion: Coils: The name or trademark of the manufacturer and ACR shall be permanently incised on each tube 1/4" **or larger** at Intervals not greater than 1 1/2 ft. Hard Straight Lengths: The name or trademark of the manufacturer and a mark indicating either L or ACR shall be incised at intervals not greater than 1 1/2 ft. along the length of the tube.

Hard straight lengths shall further be marked with a blue stripe containing the manufacturer's name or trademark, the nation of origin, outside diameter and ACR repeating at intervals not greater than 3 ft.

Air conditioning and refrigeration tube (ASTM B 280) either coiled or straight length is further required to be cleaned and capped prior to shipping.

- Threadless Copper Pipe (TP)

Threadless copper pipe, often referred to as TP pipe, is a seamless copper pipe material manufactured to the requirements of ASTM B 302 - Standard specification for Threadless Copper Pipe, Standard Sizes. This pipe may be manufactured from either of two alloys, C10300 or C12200 with C12200 being the most popular. Both of these alloys are composed of copper (Cu) concentrations in excess of 99.9% thereby making this material an almost pure copper product. Threadless copper pipe (TP) is manufactured in drawn temper (hard) only and is furnished in H58 temper in nominal or standard sizes 1/4" through 12". The outside diameter of threadless copper pipe (TP) is essentially the same as schedule 40 pipe, although the wall thickness is much less than that for the same size pipe. The available lengths for threadless copper pipe is 20 foot for sizes 1/4" to 10" with 12" being furnished in 15 foot lengths.

Threadless copper pipe (TP) is required, by the standard, to be identified by a gray colored stripe throughout its length that contains the manufacturers name or trademark, the nation of origin and "TP". It is further required to be incised at intervals

not less than 1½ feet with the manufacturers name or trademark and "TP" throughout its entire length.

Threadless copper pipe (TP) is usually joined by brazed socket-cup type fittings or socket-cup type flanges. It should be noted that standard copper pressure fittings of the B16.22 or B16.18 type are not compatible for use with TP pipe.

- Copper Drainage Tube

Seamless copper tube used for sanitary drainage, waste and vent systems in plumbing applications is often referred to as "DWV" tube and is manufactured to the requirements of ASTM B 306 - Standard Specification for Copper Drainage Tube (DWV). DWV tube is manufactured from alloy C12200 that is 99.9% copper (Cu) and has a phosphorous (P) content of between 0.015% to 0.040%. DWV copper tube is furnished in H58 drawn (hard) temper only, in sizes 1¼" through 8". The standard length for DWV tube is 20 foot, however other lengths may be provided through prior agreement between the purchaser and the manufacturer. DWV copper tube shall be identified in two manners. The first is by an incised mark, at intervals not greater than 1½ feet, containing the manufacturers name or trademark and "DWV". The second is by a continuous yellow stripe containing the manufacturer's name or trademark, the nation of origin and "DWV" to be repeated at intervals not greater than 3 feet. Soldering of drainage pattern fittings meeting the ASME/ANSI B16.23 or B16.29 standards is the usual manner for joining DWV tube.

- Welded Copper Tube

This is a copper tube that is manufactured from either sheet or strip and has a longitudinal seam that is free of any type of filler metal and is usually manufactured to the requirements of ASTM B 447 - Standard Specification for Welded Copper Tube.

Welded copper tube may be manufactured from any of the following alloys of copper: C10100, C10200, C10300, C10800, C11000, C12000, C12200, or C14200. Unless it is specifically specified in the contract for manufacturer any of the listed alloys shall be considered acceptable; however welded copper tube manufactured from alloy C11000 may not be used in applications where hydrogen embrittlement may occur. Welded

copper tube may be furnished in the annealed (soft), O60, O50 or drawn (hard) temper in sizes and lengths specified by the purchaser.

Essentially this tube is an engineered type tube where the purchaser must specify the type of copper alloy, the form of the tube (straight length or coil), temper, internal flash treatment, and dimensions (diameter, wall thickness, length).

- Welded Brass Tube

Welded brass tube may be provided in either round, rectangular or square form and is manufactured to the requirements of ASTM B 587 - Standard specification for Welded Brass Tube for engineered applications.

Welded brass tube may be manufactured from any one of the following copper alloys: C21000, C22000, C23000, C26000, C26800, C27000, or C27200. the copper(Cu) content of these alloys ranges from 62.0% to 96.0% depending on the alloy chosen.

Essentially this tube is an engineered type tube where the purchaser must specify the type of copper alloy, the form of the tube (straight length or coil), dimensions, (distances between parallel surfaces if square or rectangular, inside and outside diameter if round), wall thickness, overall length, and temper.

- Medical Gas Tube

Seamless copper tube used for the installation of nonflammable medical gases (and in some cases high-purity applications) where the gases being delivered are not considered flammable is manufactured to the requirements of ASTM B819 - Standard Specification for Seamless Copper Tube for Medical Gas Systems.

Medical gas tube may be provided in one of two types, type K or type L, in drawn (hard) H58 temper only. (Both of these types are defined and described in ASTM B88.) Alloy C12200 is the only alloy permitted for use for medical gas tube and is a minimum 99.9% pure copper (Cu) and silver (Ag) combined with no greater than 0.040% phosphorous (P).

Medical gas tube is required to be cleaned, by the manufacturer, so that the maximum interior surface residue does not exceed 0.0035 g/ft² of interior surface. Cleaning

techniques may be found in CGA G4.1 although the manufacturer is not limited to those procedures or practices. Medical gas tube is required, by the ASTM B 819 standard, to be identified with a continuous stripe of either green for type K or blue for type L containing the type of tube, the manufacturers name or trademark, the nation of origin at intervals not to exceed 3 feet. It is further required to be incised with the type of tube, the manufacturers name or trademark at intervals not to exceed 1½ foot. Acceptable additional required markings in the color appropriate for type K (green) or type L (blue) shall be "OXY", "MED", "OXY/MED", "OXY/ACR", "ACR/MED".

- Fuel Gas Tube

Seamless copper tube for fuel gas installations of natural gas or liquefied petroleum (LP) can, in some jurisdictions, use tube manufactured to the requirements of ASTM B 837 - Standard specification for Seamless copper Tube for Natural Gas and Liquefied Petroleum (LP) Gas Fuel Distribution Systems. This tube is manufactured from alloy C12200 that is 99.9% copper (Cu) and silver (Ag) combined and has a phosphorous (P) content of between 0.015% to 0.040% making it an almost pure copper material.

(It should be noted that ASTM B837 copper tube is not permitted for use by NFPA 54 - National Fuel Gas Code as an acceptable copper tube material for fuel gas applications and adherence to applicable model, local, state and federal codes should be referred to prior to its use.)

This tube is furnished in annealed (soft) (O60) temper in sizes 3/8" O.D. through 7/8" O.D. and in drawn (hard) (H58) temper in sizes 3/8" O.D. through 1 1/8" O.D.. Coils may be provided in 60 or 100 foot lengths while straight lengths may be provided in 12 or 20 foot lengths. Longer lengths may be provided upon prior agreement between the manufacturer or supplier and the purchaser.

This tube is required to be permanently marked (incised) with the mark "Type GAS" and the name or trademark of the manufacturer at intervals not to exceed 18 inches. Additionally, drawn (hard) temper straight lengths of tube shall be identified by a yellow colored stripe containing the type of tube, name or trademark of the manufacturer or both, and the country of origin. [20]

9.6.3. WIRES

9.6.4. SECTIONS

Sections are semi-finished products from which functional parts are manufactured in the majority of cases at very low processing costs. With sections it is possible to reduce production costs, and consequently, total costs. Due to their excellent electrical and thermal conductivity, copper sections are mainly used in the electrical industry and in cooling systems. [20]

10. COPPER BY PRODUCTS

Just as metals are rarely found in pure form, the same is true of minerals. Moreover, certain combinations are apparently preferred by nature. This is especially true of the sulfide ores of heavy metals. Lead and zinc and a number of other metals, are almost invariably found in copper ores (in trace amounts, to be sure) and conversely. Most lead mines also produce zinc, and conversely. Molybdenum, nickel and cobalt are also commonly found with copper, though copper is generally a by-product of these metals and not the primary product.

A number of other metals are obtained partly or largely from copper. Some of these metals (e.g. gold and silver) are economically very important. Others are important because of their toxicity (e.g. arsenic, cadmium, thallium) and still others (e.g. antimony, bismuth, selenium) have small but significant current market niches or (like bismuth, germanium, indium, rhenium, tellurium, thallium) they may have future importance in specialized electronic applications. [21]

11. COPPER RECYCLE

For thousands of years, copper and copper alloys have been recycled. This has been a normal economic practice, even if regretted by some. One of the wonders of the old world, the Colossus of Rhodes, a statue spanning the entrance to Rhodes Harbor, was said to have been made of copper. No trace of it remains since it was recycled to make useful artefacts.

In the middle Ages it was common that after a war the bronze cannons were melted down to make more useful items. In times of war even church bells were used to produce cannon.

The entire economy of the copper and copper alloy industry is dependent on the economic recycling of any surplus products. There is a wide range of copper based materials made for a large variety of applications. To use the most suitable and cheapest feedstock for making components gives the most economic cost price for the material. [22]

Scrap Value - Copper

The usual commercial supplies of pure copper are used for the most critical of electrical applications such as the production of fine and superfine enamelled wires. It is essential that purity is reproducibly maintained in order to ensure high conductivity, consistent annealability and freedom from breaks during rod production and subsequent wire drawing. Since the applied enamel layers are thin but have to withstand voltage, they must have no surface flaws; consequently the basis copper wire must have an excellent surface quality. Primary copper of the best grade is used for producing the rod for this work. Uncontaminated recycled process scrap and other scrap that has been electrolytically refined back to grade 'A' quality may also be used.

The copper used for power cables is also drawn from high conductivity rod but to a thicker size than fine wires. The quality requirements are therefore slightly less stringent. The presence of any undesirable impurities can cause problems such as hot shortness which gives expensive failures during casting and hot rolling. For the same reason, scrap containing such impurities can only be used for this purpose if well diluted with good quality copper.

For non-electrical purposes, copper is also used to make large quantities of plumbing tube, roofing sheet and heat exchangers. High electrical conductivity is not mandatory and other quality requirements are not so onerous. Secondary copper can be used for the manufacture of these materials, though still within stipulated quality limits for impurities.

Where scrap copper is associated with other materials, for example after having been tinned or soldered, it will frequently be more economic to take advantage of such contamination than try to remove it by refining. Many specifications for gunmetals and bronzes require the presence of both tin and lead so this type of scrap is ideal

feedstock. Normally it is remelted and cast to ingot of certified analysis before use in a foundry. Scrap of this type commands a lower price than uncontaminated copper.

Scrap Value - Brasses

The recycling of brass scrap is a basic essential of the economics of the industry. Brass for extrusion and hot stamping is normally made from a basic melt of scrap of similar composition adjusted by the addition of virgin copper or zinc as required to meet the specification before pouring. The use of brass scrap bought at a significantly lower price than the metal mixture price means that the cost of the fabricated brass is considerably less than it might otherwise be.

The presence in brass of some other elements such as lead is often required to improve machinability so such scrap is frequently acceptable. Besides the common free-machining brasses, there are many others made for special purposes with properties modified to give extra strength, hardness, corrosion resistance or other attributes, so strict segregation of scrap is essential.

Brass scrap arising from machining operations can be economically remelted but should be substantially free from excess lubricant, especially those including organic compounds that cause unacceptable fume during remelting.

When brass is remelted, there is usually some evolution of the more volatile zinc. This is made up in the melt to bring it back within specification. The zinc is evolved as oxide that is drawn off and trapped in a baghouse and recycled for the manufacture of other products.

Brass to be made in to sheet, strip or wire form must be significantly free of harmful impurities in order to retain ductility when cold. It can then be rolled, drawn, deep drawn, swaged, riveted, spun or otherwise cold formed. It is normal therefore to make it substantially from virgin copper and zinc, together with process scrap arising from processing that has been kept clean, carefully segregated and identified.

Scrap Value - Other Copper Alloys

Copper alloys such as phosphor bronzes, gunmetals, leaded bronzes and aluminium bronzes are normally made to closely controlled specifications in order to ensure fitness for demanding service. They are normally made from ingots of guaranteed composition together with process scrap of the same composition that has been kept carefully segregated. Where scrap has become mixed, or is of unknown composition, it is first remelted by an ingot maker and analysed so that the composition can be suitably adjusted to bring it within grade for an alloy.

Good quality high conductivity copper can be recycled by simple melting and check analysis before casting, either to finished shape or for subsequent fabrication. However, this normally only applies to process scrap arising within a copper works. Where copper has been contaminated and it is required to re-refine it, it is normally remelted and cast to anode shape so that it can be electrolytically refined. If, however, the level of impurities in the cast anode is significant, it is unlikely that the cathode produced will then meet the very high standards required of grade 'A' copper used for the production of fine wires.

Where copper and copper alloy scraps are very contaminated and unsuitable for simple remelting, they can be recycled by other means to recover the copper either as the metal or to give some of the many copper compounds essential for use in industry and agriculture. This is the usual practice for recovery of useable copper in slag, dross or mill scale arising from production processes or from life-expired assemblies of components containing useful quantities of copper.

Environmental Considerations

Copper is an essential trace element needed for the healthy development of most plants, animals and human beings. In general, moderate excess quantities of copper are not known to cause problems. Every care is taken to avoid wasting copper and it is recycled where possible. Excess copper is not allowed to escape into the atmosphere as fume, nor into discharged process cooling water, all of which is generally treated to keep within agreed limits.

Other metals associated with copper alloys are generally not in a form that is dangerous. However, when fume is generated, for example by melting or welding, it

may be necessary to use fume extraction equipment. Beryllium is sometimes used as an alloying element in copper to make some of the strongest copper alloys known, being invaluable for the production of heavy duty springs. When alloyed with copper and in the solid state this presents no health hazard. However, if present in the atmosphere, beryllium can cause a health hazard and should be controlled. CDA publication 104 gives advice on health and safety requirements for airborne fume associated with copper-beryllium.

Product Value

If the scrap is pure copper and has not been contaminated by anything undesirable, a high quality product can be made from it. Similarly, if scrap consists only of one alloy composition it is easier to remelt to a good quality product, although there may have to be some adjustment of composition on remelting.

If scrap is mixed, contaminated or includes other materials such as solder then, when remelted, it will be more difficult to adjust the composition within the limits of a chosen specification. Where lead or tin have been included, but no harmful impurities, it is usually possible to adjust composition by the addition of more lead or tin to make leaded bronzes. For some scrap contaminated with undesirable impurities it is sometimes possible to dilute it when melting so that the impurity level comes within an acceptable specification. All these techniques retain much of the value of the scrap. The way in which alloys can be made from scrap is shown in simplified diagrammatic form in the figure.

Where scrap has been contaminated beyond acceptable limits it is necessary to re-refine it back to pure copper using conventional secondary metal refining techniques that provide a useful supplement to supplies of primary copper.[22]

11.1. BENEFITS OF RECYCLING COPPER

Copper recycling and reuse

- Reduce: Copper products are hard wearing and last for a long time and will often still function long after they have been superseded by newer models.
- Reuse: Goods such as mobile phones, washing machines and cookers, which are still in working order, can be passed on to others for reuse.
- Recycling: Copper containing waste such as WEEE (Waste Electrical and Electronic Equipment), electrical cables, old taps, copper plumbing pipes and scrap from copper/copper alloy production and manufacturing is collected, dismantled and sorted. This is followed by melting, casting and the manufacture of new copper products. [23]

In Europe, 41% of the demand for copper is met from recycling.



Figure 67. Copper Scrap
Source: owlmetals.com

The economic and environmental benefits of recycling copper are given below and illustrate the sustainable nature of copper:

- Environment

During mining and refining (purification) of copper, dust and waste gases such as sulfur dioxide are produced which may have a harmful effect on the environment. Although these harmful effects are minimized by copper producers (sulfur dioxide

is captured and used to make sulfuric acid), with recycling there are little, if any, harmful gases emitted.

- Landfill costs

Copper and copper alloy objects which are not recycled might otherwise be dumped in holes in the ground - this is called landfill. These holes are rapidly being filled up and, as they become scarcer, landfill becomes a very expensive option for waste disposal (of any material).

- Energy saving

In order to extract copper from copper ore the energy required is approximately 100GJ/ton. Recycling copper uses much less energy, about 10GJ/ton, that's only 10% of the energy needed for extraction. This energy saving leads to the conservation of valuable reserves of oil, gas or coal and reduces the amount of CO₂ released into the atmosphere.

- Conservation of copper ore

Today only about 12% of known copper resources have been mined. However copper ore is a finite resource and it makes sense to conserve ore by recycling.

- Economics

It is cheaper to recycle old copper than to mine and extract new copper. Recycled copper is worth up to 90% of the cost of the original copper. Recycling helps to keep the cost of copper products down. [23]

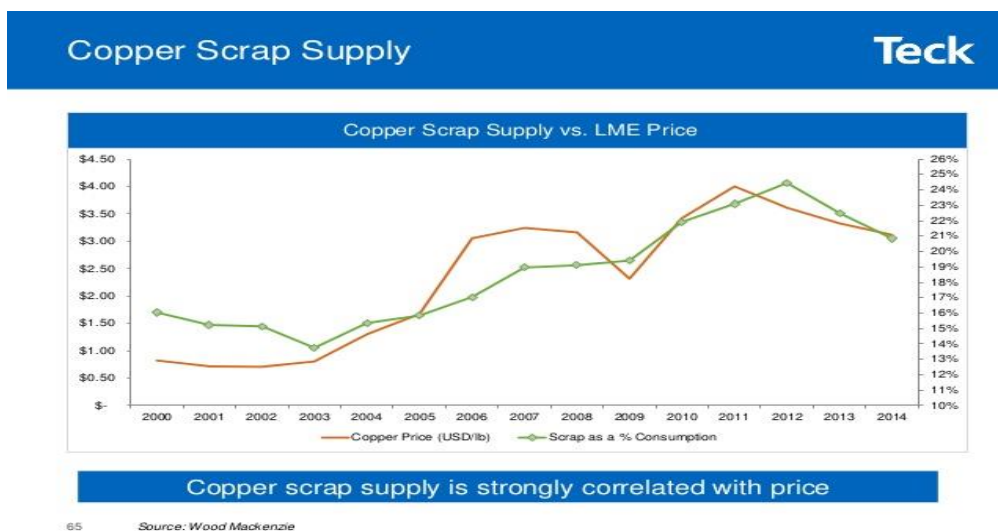

Figure 68. Copper Scrap Supply

Source: Wood Mackenzie

11.2. PRETREATMENT OF SCRAP COPPER

Copper electric wire encased in insulation

The copper electric wire is of very high purity but encased in insulation which must be removed. This can be removed from the wire by stripping it off in the normal manner you would use when rewiring a plug. It can also be removed by chopping up the wire and the cable into small pieces. These are fed into shakers and mesh screens where most of the insulation will come away from the wire. Various types of plastic insulation can also be segregated for recycling, both methods being highly automated and efficient at insulation removal and separation from the copper wire. Following these processes, the copper wire is then washed in a diluted acid mix to remove any lacquer or impurities.

Copper windings in electric motors, generators and starters

The removal of copper from electric motor windings is very labor intensive and time consuming, however, an innovative method is under research where the windings are subjected to very low temperatures. This makes the copper wire brittle, enabling it to be broken away from the winding frames in small pieces before it is washed in a light acid mix to remove lacquer.

Copper piping and tanks

Copper piping and tanks are immersed in a light acid bath, then washed in water. They may also be flattened after this stage.

Copper alloys

Components made from copper alloys such as brass, bronze and nickel make up a high percentage of recycled copper. The components are immersed in light acid, washed with water and segregated into their separate categories according to their alloyed metals of tin, lead and zinc. They remain in this state for transportation to the recycling furnaces.

Recycling of copper alloys is carried out in a furnace, where the alloys are added to pure copper ingots to achieve grade of copper with certain required properties. Where there are too many trace elements in the alloys, they are melted separately, usually in an electric furnace, where the minor trace elements are removed from the molten metal, before pouring into ingots.

Copper alloy can also be recycled by adding more pure copper, thus diluting the alloyed metals to an acceptable level.

Copper shavings from machine operations

Cuttings and swarf from machining copper will be contaminated with coolant oil, which is removed by immersion in a light acid bath after which it is washed in water.

Shredding and compacting

Once all the scrap copper has been recovered and treated, it is shredded and compacted into bales. These bales, along with the copper alloy components, are shipped to a copper smelter or remelting facility. [24]

11.3. METHODS OF COPPER SCRAP RECYCLING

There are two basic copper recycling methods:

- Melting at a copper smelter along with copper ore
- Melting along with a proportion of copper ingots at a dedicated copper recycling plant

At a copper smelter, the scrap copper and alloy components are loaded into the furnace which is then fired up. The copper ore is fed into the furnace along with the required amount of limestone and sand. Oxygen and air are supplied and when the mix has become molten, it is then tapped into rectangular molds. The resultant rectangular plates are then purified to 99.9% pure copper using electrolysis processing.

At a copper recycling plant, the bales of compacted copper along with the required content of alloys are loaded into a furnace along with a proportion of pure copper ingots.

The furnace can either be of an electric induction type or a reverberatory one. The electric furnace melts all the contents and tips to pour the molten copper through a spout into molds for either further processing or they are shipped to a copper smelter.

A reverberatory furnace is a square box structure lined with firebricks and is usually gas fired, having a loading door at the front which can be lowered or raised as required. Once the copper is molten, samples are taken, and when approved, the molten copper is poured into molds and left to cool. The resultant copper ingots can be sent for further refining or dispatched to a copper smelter for further processing.

The resultant ingots or rectangular plates are subjected to an electrolysis process where the end product is 99.9% pure copper. [23]

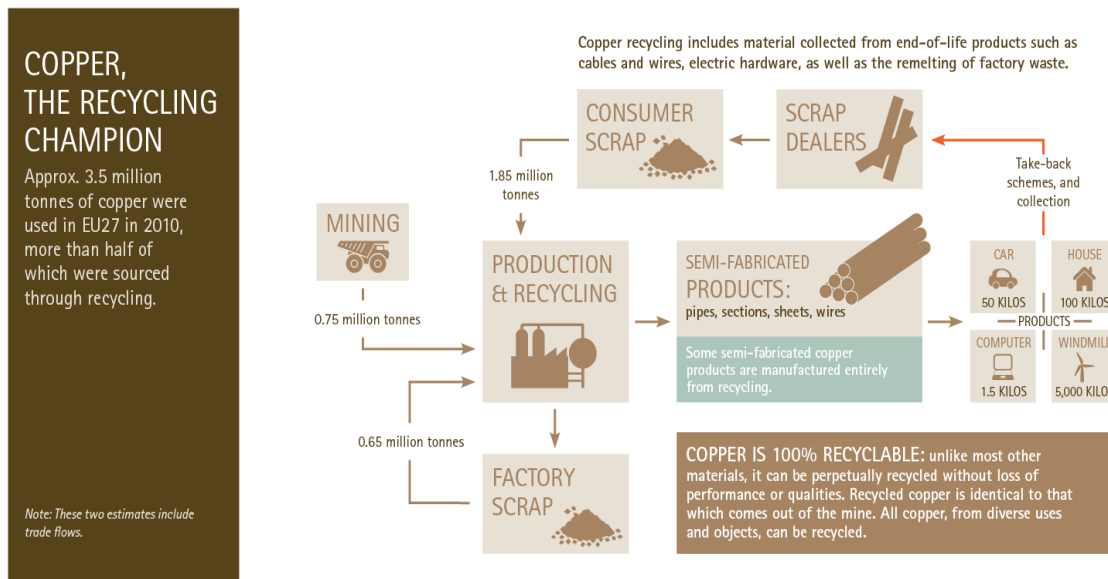

Figure 69. Copper Recycling Chain

Source: European Copper Institute, copper Alliance

11.4. COPPER SCRAP SOURCES

No. 1 Scrap copper. It consists of uncoated, clean, unalloyed copper and can include punchings, clippings, bus bars, pipe, wire over 1/16' thick with no burnt or brittle wire and commutator segments.

No. 2 scrap copper. It consists of clean, non-alloyed copper. It needs to be clean, but can be oxidized or coated clippings, bus bars, punchings, commutator segments. It can also include clean oxidized pipe or tubing, but should be free of excessive solder. Light gauge, clean, coated or oxidized wire is also allowed, but must be free of fine gauge wire. All No. 2 scrap copper should be free of excessive oxidization, ash, brittle burnt wire and scale.

The third category of scrap copper is soldered copper pipe scrap. It can consist of any length of copper pipe that has soldered joints. It should be free of bronze or brass fittings or any other fittings that are not made of copper.

Beryllium copper scrap consists of solid beryllium alloyed copper. It can be in the form of clippings, pipe, tubing and elbows, bar or punchings. Beryllium copper brings the fourth highest price for recycled copper.

Light scrap copper contains unalloyed copper solids and can include sheet copper, downspouts, gutters, foil, unburned hair wire, boilers and kettle. Light scrap copper is generally any thin gauge scrap copper or solid copper with a high surface area that has only surface oxidation. The minimum re-melt recovery rate for light scrap copper is 88%.

Copper Turnings are recovered from unalloyed grindings, borings or turnings and they may be contaminated with cutting oils.

No. 1 Bare bright copper wire is uncoated, unalloyed, bare copper wire that is larger than 16 gauge. Green wire is not allowed in this category.

No. 1 Copper wire scrap is recovered from clean, unalloyed, uncoated wire that is no smaller than 16 gauge.

No. 2 Copper wire scrap includes only unalloyed, clean copper wire. Hair wire, burnt and brittle wire and any wire that has excessive oils on it is not allowed. The minimum content within the re-melt recovery rate of No. 2 copper wire scrap is 94%.

No. 1 Copper wire nodules consist of No. 1 bare, unalloyed, uncoated copper wire nodules that are gathered from choppings or shredding and are no smaller than 16 gauge. No. 1 copper wire nodules provide a 99% content re-melt recovery rate.

No. 2 Copper wire nodules provide a 97% minimum copper content in the re-melt recovery rate. This category consists of No. 2 copper wire nodules that are unalloyed and are from a shredding or chopping operation.

No. 1 Insulated copper wire scrap is recycled from plastic insulated, uncoated or plated, unalloyed wire that is larger than 16 gauge.

No. 2 Insulated copper wire scrap consists of different plastic insulated, unalloyed copper wire, which is free of double insulation or heavy insulation.

No. 3 Insulated copper wire scrap is made up of assorted unalloyed copper wire that is plastic insulated and includes telephone cable and heavy or double insulated wire.

The Copper/Aluminum BX cable scrap category is made up of plastic insulated copper wire that is coated with aluminum casing.

Copper/Steel BX cable scrap is taken from plastic insulated copper wire that is coated with a steel casing.

The scrap copper/fractional electric motors category includes less than 1 horsepower electric motors and small copper coil windings.

Scrap copper/large electric motors are in a category consisting of large copper coil windings. These motors are over 1 horsepower.

Scrap copper/sealed motors consist of compressor motors from refrigerators and freezers. These motors are also sealed.

Scrap copper/aluminum rods are unalloyed copper tubing that is surrounded by cooling fins made of aluminum. They generally come from heat exchange radiators.

Copper content scrap contains, by weight, not less than 30% copper. Plating racks, laminated items, irony copper, brittle burnt wires, copper scale, comutators and armatures are generally in this category. [25]

11.5. EUROPE DEMAND FOR RECYCLED COPPER

According to the International Copper Study Group (ICSG), about 50% of the copper used in Europe comes from recycling. This reveals our copper requirements are increasingly being met by metals recycling. This win-win situation is helping to supply our ever-increasing demand for the metal (+250% since the 1960s) while, at the same time, lessening the environmental impact of its production and ensuring sustainability and availability for generations to come. A computer contains around 1.5 kg of copper, a typical home about 100 kg and a wind turbine 5 tons. Considering copper can be fully recycled and reused again and again, without any loss of performance, we have every incentive to ensure our products and copper waste are correctly processed when they reach the end of their useful lives. After all, the copper from one's smartphone could end up as part of the water system in one's home. Copper recycling and waste management have become an important part of the supply chain, keeping resources local, creating local jobs, saving on landfill site space and incentivising the recycling of other materials.

In 2014, 2.1 million tons of copper were reused in Europe, coming from end-of-life products and directly-recycled factory waste. This increased recycling of copper is being driven by the growth in use of the metal across the planet and by demand for world class European companies' pioneering technologies allowing for increased efficiency in refining secondary (low grade) scrap and in processing for direct melt high purity copper scrap. Copper is omnipresent in the equipment modern life depends upon more and more, namely high-tech products, electrical installations, engines, solar systems and smart buildings. Read more in the Applications section. Since the mid-1960s, global demand for refined copper has increased by over 250% (from 5 million to 20 million tons). Mine production remains vital in order to meet this growing demand. Ensuring that sufficient copper will be available to meet society's

future needs will require increased levels of recovery and recycling, as well as substantial investments in mining. [10]



Figure 70. Copper Recycling

Source: European Copper Institute, copper Alliance

12.COPPER PRODUCTION

12.1. WORLD COPPER PRODUCTION

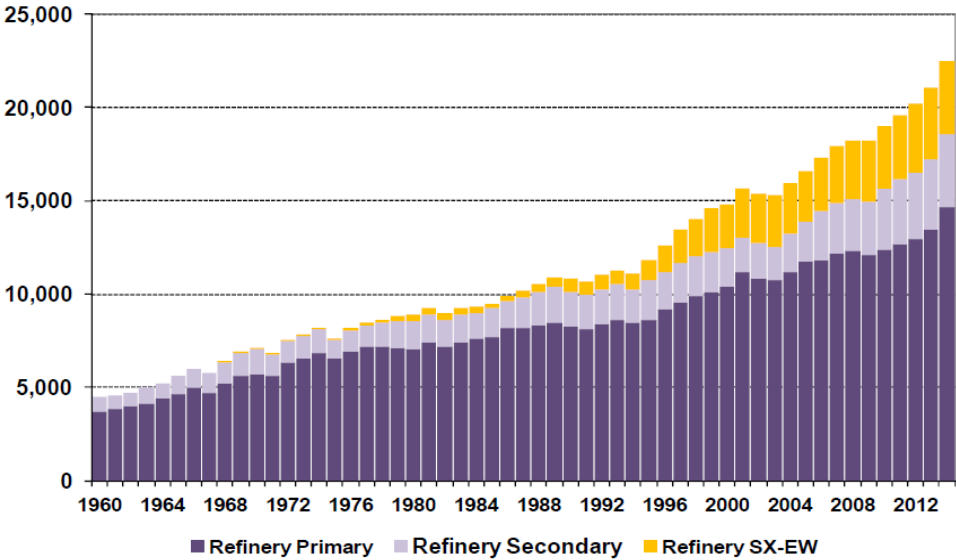

Figure. 71: World Refined Copper Production, 1960- 2014
 Thousand metric tons
 Source: ICSG

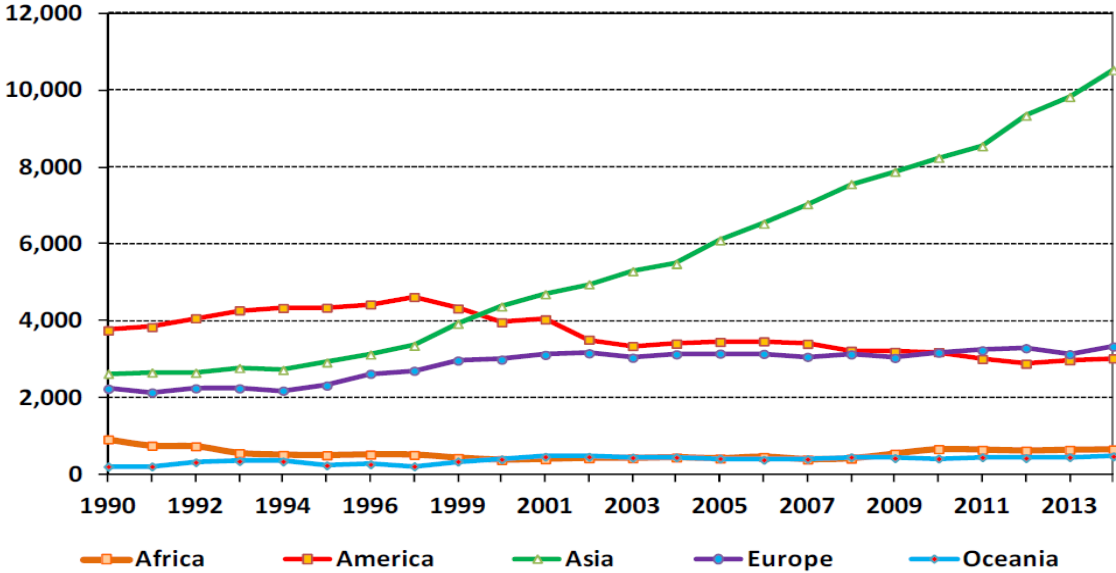
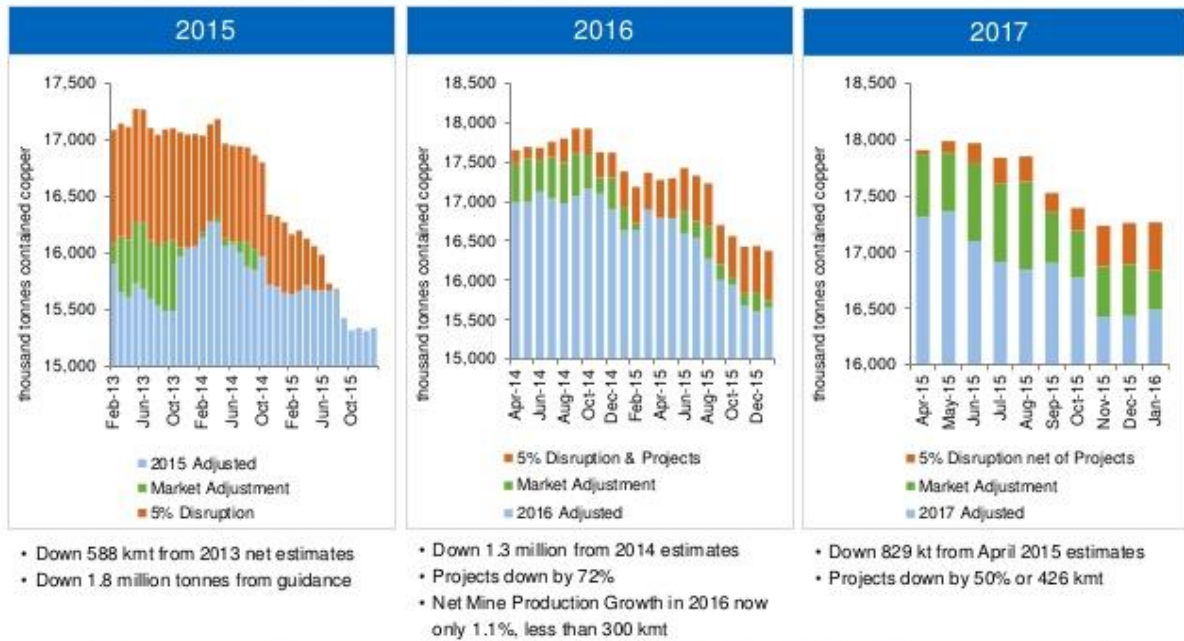

Figure. 72: Copper Smelter Production by Region, 1990-2014
 Thousand metric tons
 Source: ICSG

Copper Mine Production Forecasts Continue to Decline



Losses in 2016 already 72% of 2015 levels

57 Source: Wood Mackenzie

Figure 73. Copper Mine Production
Source: Wood Mackenzie

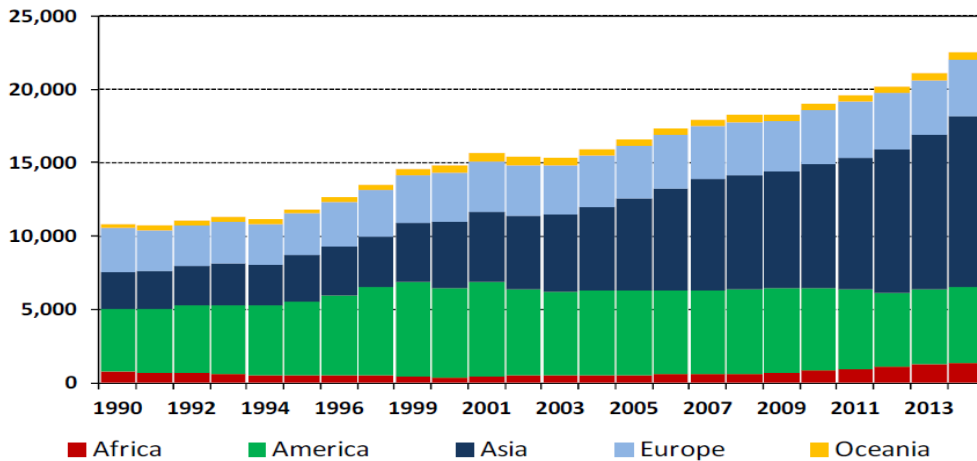

Figure 74. Refined Copper Production by Region, 1990-2014

Thousand metric tons

Source: ICSG

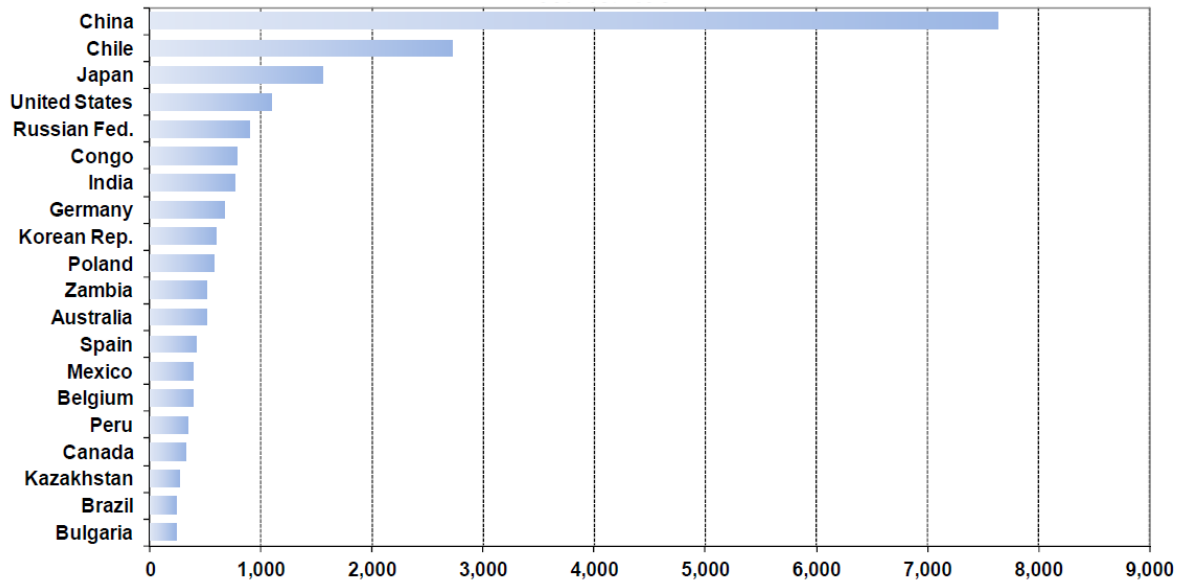

Figure 75. Refined Copper Production by Countries, Top Countries in 2014

Thousand metric tons

Source: ICSG

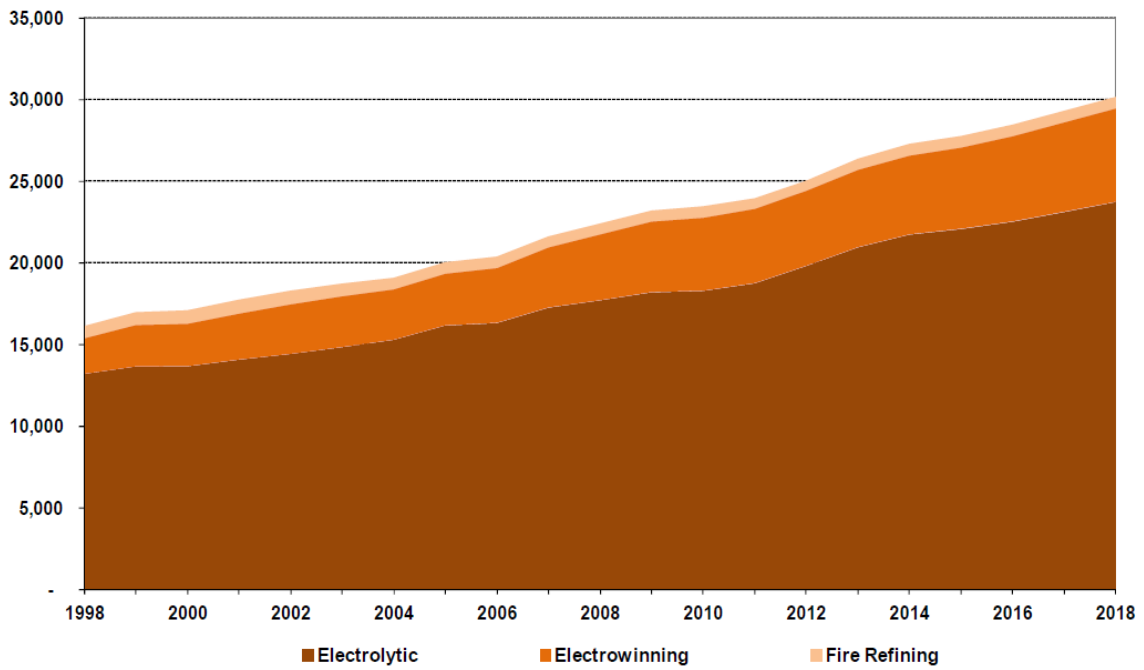

Figure 76. Trends in Refined Capacity, 1998-2018

Thousand metric tons copper

Source: ICSG Directory of Copper Mines and Plants - July 2015

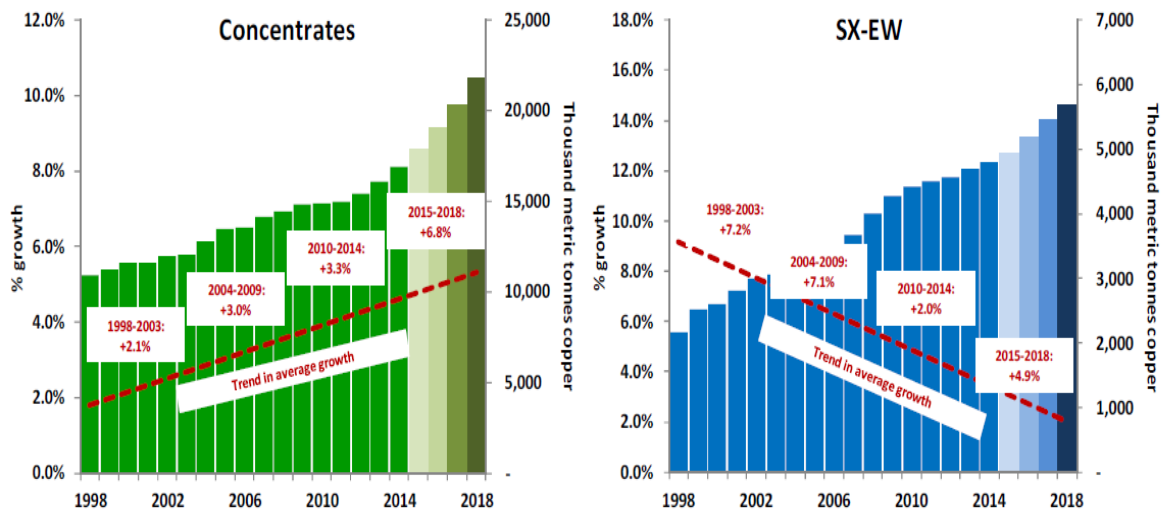

Figure 77. Trends in Copper Mining Capacity, 1998- 2018
 Thousand metric tons (Bars) and Annual percentage change (Line)
 Source: ICSG Directory of Copper Mines and Plants – July 2015

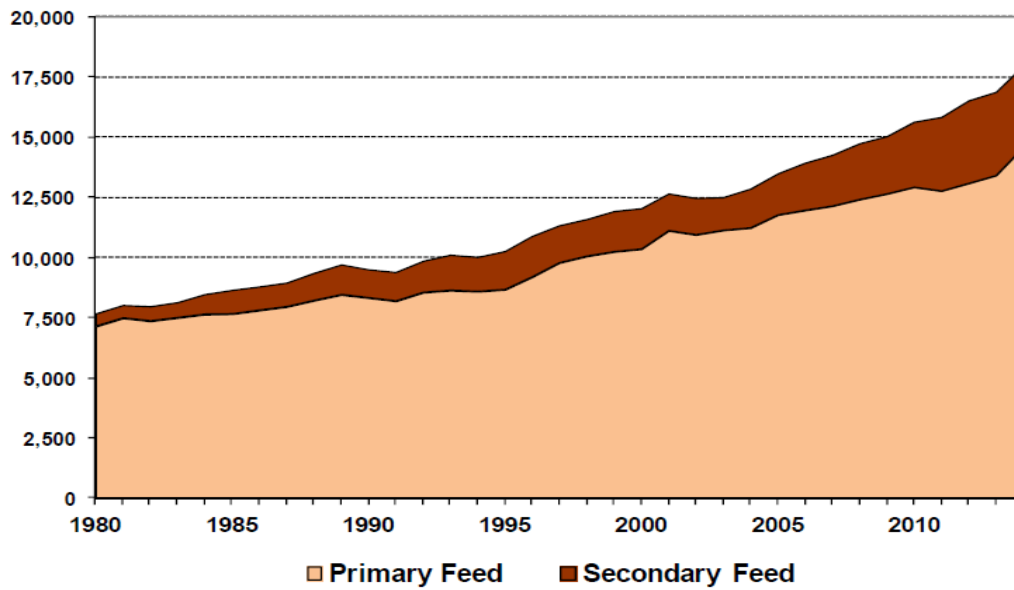

Figure 78. World Copper Smelter Production, 1980-2014
 Thousand metric tons copper
 Source: ICSG

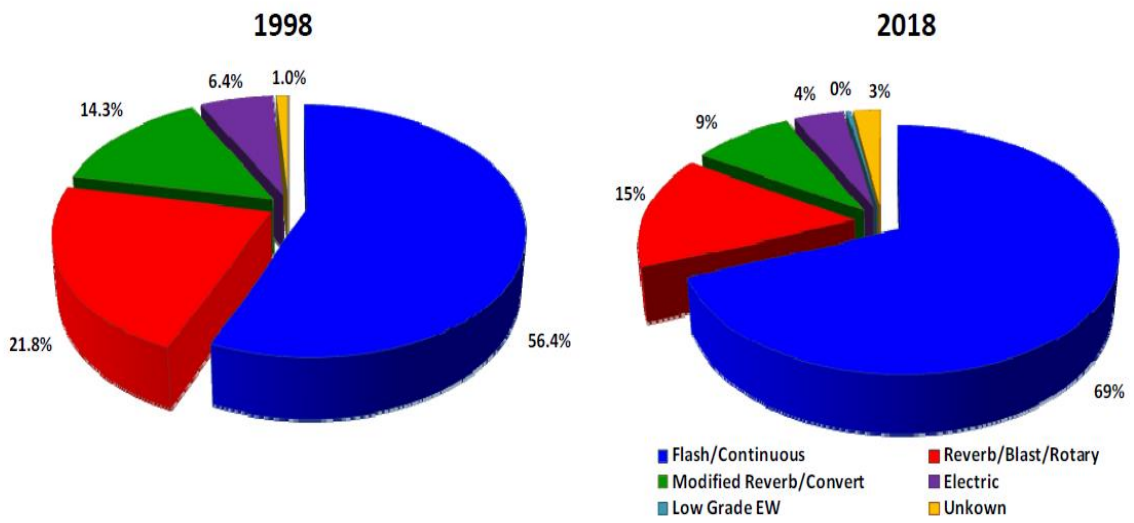

Figure 79. Trends in Copper Smelting Capacity, 1998 and 2018
 Percentage share of total capacity, by technology type
 Source: ICSG Directory of Copper Mines and Plants – July 2015

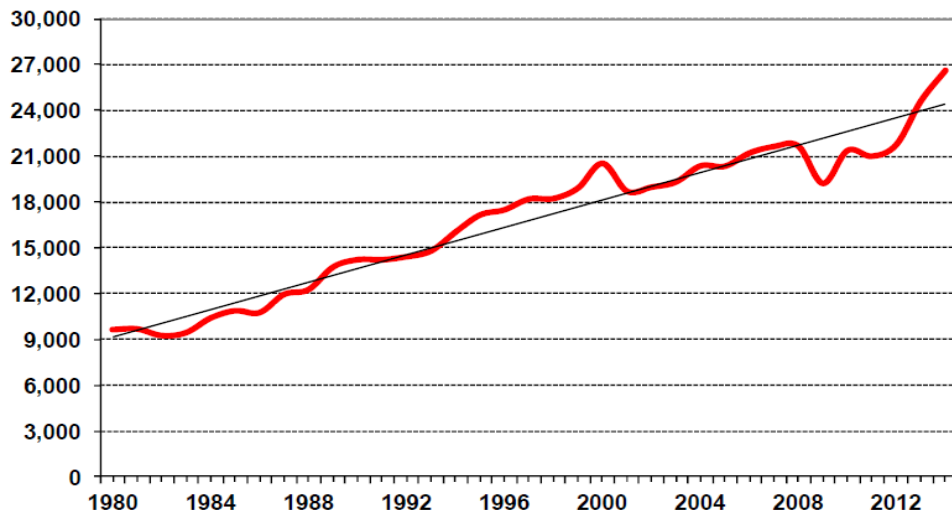

Figure 80. World Copper and Copper Alloy Semis Production, 1980- 2014P
 Thousand metric tons
 Source: ICSG

12.2. IRAN COPPER PRODUCTION

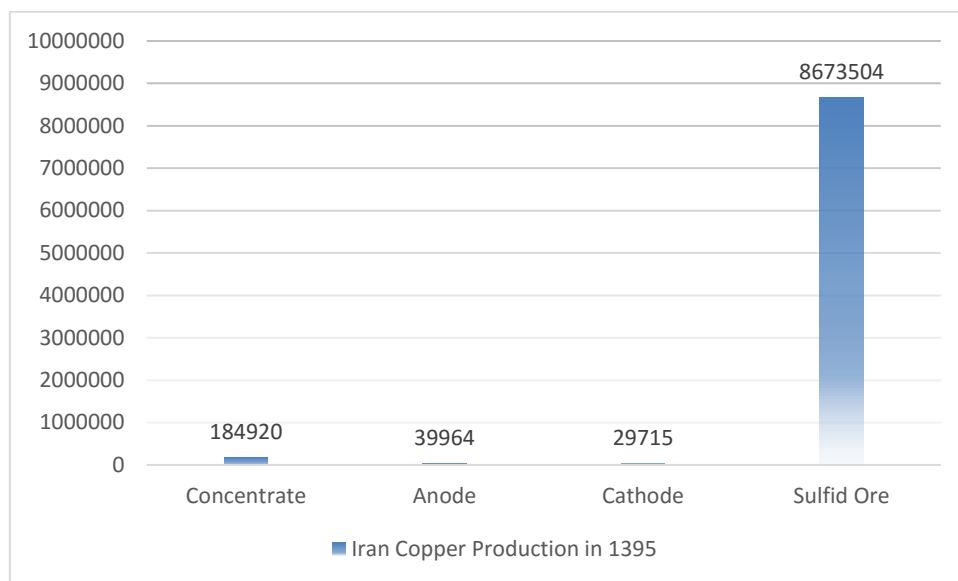

Figure 81. Iran Copper Production in Two Months in 1395

Source: Minews.com

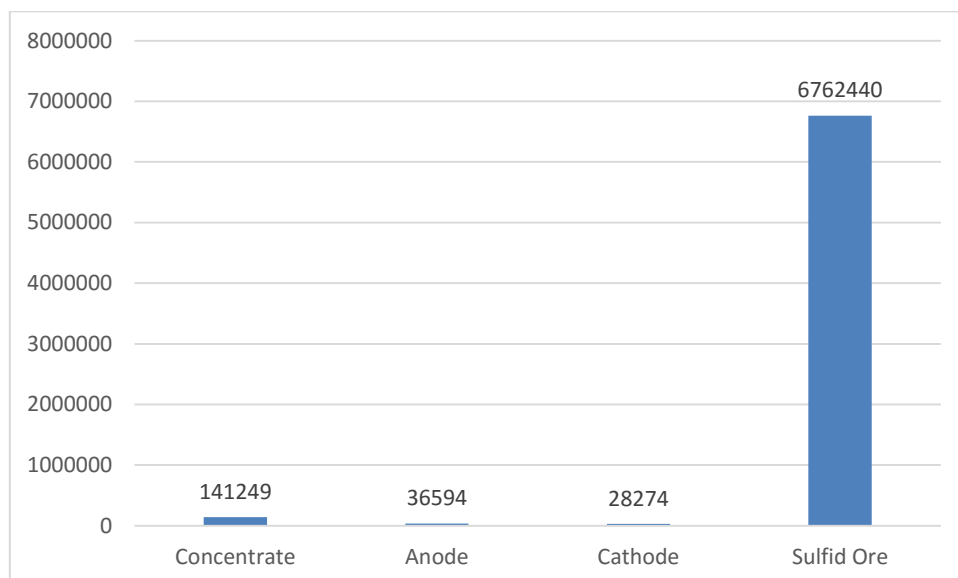

Figure 82. Iran Copper Production in Two Months in 1394

Source: Minews.com

12.2.1. IRAN COPPER CONCENTRATE

Table 6. Name and Capacity of Iran Concentrate Producers

Source: Ministry of Industry, Mine and Trade

ROW	NAME	PROVINCE	NOMINAL CAPACITY
1	Khorasan Tarsis Copper	Razavi Khorasan	2,500 ton
2	Taknar Copper Mines Complex	Razavi Khorasan	1,600 ton
3	Kani mes Part Shargh	Razavi Khorasan	7,900 ton
4	Chahar Gonbad	Kerman	5,000 ton
5	Rangin Mes Felez	Kerman	18,000 ton
6	Kian Mes Jozam	Kerman	1,250 ton
7	Chek Rize	Kerman	1,500 ton
8	Ghale Zari	South Khorasan	10,000 ton
9	Songun	East Azarbaiejan	150,000 ton
10	Miduk	Kerman	150,000 ton
11	Sarcheshmeh	Kerman	300,000 ton

12.2.1.1. GHALE ZARI BENEFICIATION

This plant has been constructed Ghale Zari with nominal capacity of the plant is 420 tons per day, the main economic minerals mining are chalcopyrite, malachite and azurite. Ore grade is nearly 1% copper which is processed with 94 to 98 percent efficiency and 16% copper grade. [35]



Figure 83. Ghaleh Zari Beneficiation

Source: ghalezarimine.ir

12.2.1.2. CHAHAR GONBAD BENEFICIATION

Chahar Gonbad mine is located at 80 km northeast of Sirjan and 32 km north west of Bolour. The main mineral of copper ore is Chalcopyrite and pyrite with 1.19% Copper content. [36]

12.2.2. IRAN COPPER COMPLEXES

12.2.2.1. SARCHESHMEH COPPER COMPLEX

Sarcheshmeh Copper Complex is located 160km southwest of Kerman and 50km south of Rafsanjan. The region's altitude averages about 2600m, the highest spot of which approximates 3000m. Sarcheshmeh ore bodies, situated in the central part of Zagros ranges, consist of folded and faulted early tertiary volcano- sedimentary rocks. [29]

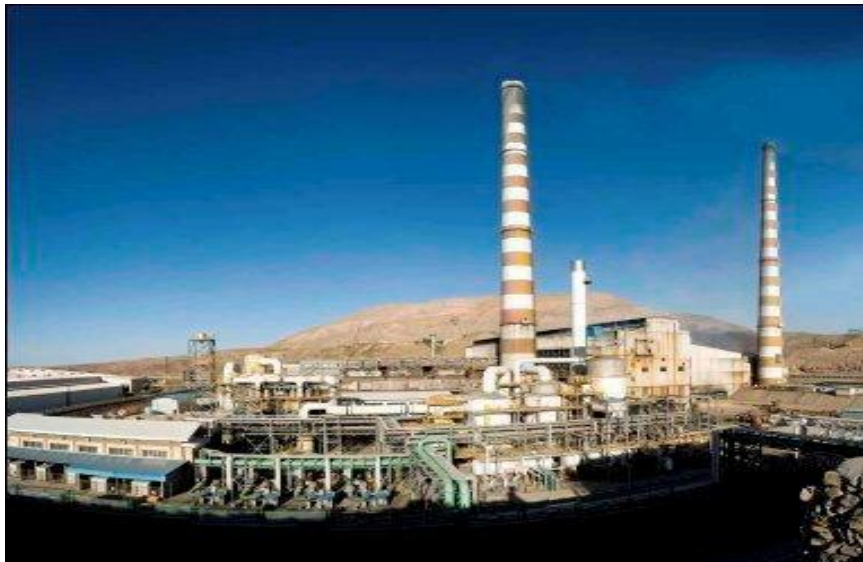

Figure 84. Sarcheshmeh Copper Complex

Source: sazehpardazi.ir

Table 6. Start up Dates of Different Sections of Sarcheshmeh Copper Complex

Commencement of Extraction Operation (Tailings Haulage)	June,1974
The First Exploitation of Dumped Sulphide Ores Near the Primary Crusher	July,1974
Transport of Sulphide Ores to the Primary Crusher	December,1981
The First Concentrator	December,1981
Lime Slacking Operation	November,1981
Smelter	June,1982
Molybdenum Plant	June,1983
Refinery	January,1983
Foundries	April,1986
Leaching Plant	June,1997
Oxygen Plant	July,2000
The Second Concentrator	June,2004

12.2.2.2. KHATOON ABAD COPPER COMPLEX

Khatoon Abad Copper Smelter is designed with annual capacity of 80,000 tons of anode copper and 300, 000 tons of sulfuric acid with contract value of 220 million US\$.

[29]



Figure 85. Khatoonabad Copper Complex

Source: mehrnews.com

12.2.2.3. SUNGUN COPPER COMPLEX

The complex is located in 291 km North of Tabriz in East Azarbaijan province and 91 km Varzeghan in mountain area. Now, this complex consists of one mine and a beneficiation line and Molybdenum factory. Sungun copper deposit is located in a mountainous area 100 kilometers north east of Tabriz, the capital of East Azerbaijan province, enjoying proximity to Armenia and Azerbaijan countries.



Figure 86. Sungun Copper Complex

Source: donya-e-eqtasad.com

The mine is estimated to have more than 700 million tons of grade 0.661% copper ore reserves.

The second phase of Sungun copper concentration plant can recover 150,000 tons of copper concentrate of 26% grade from 7 million tons of 0.66% grade copper ore extracted from the mine, doubling the plant's existing capacity to 300,000 tons. [29]

12.2.2.4. MIDUK COPPER COMPLEX

Miduk copper mine is situated at 42 kilometers North East Shahre Babak and 132 km North West of Sarcheshmeh copper mine. Physical appearance of the area is relatively round foothills of the shallow valley with a gentle slope leads. Geological reserves of 170 million tons with 83% copper deposit which is calculated that 144 million tons with grade 85% is extractable from. The grade of the mine is considered to be 25%.



Figure 87. Miduk Copper Complex

Source: aftabir.com

The project annual production is 5 million tons per year of ore and mine life is estimated 29 years based on extractive projects.

Miduk concentration plant is near the mine in an area of 14 hectares. The plant is capable of producing 5 million ton of sulfide ore, the annual average of 150 thousand tons of copper concentrate with 30% Grade. [29]

Complex	Specification
Miduk Mine	20 mt/y copper ore
Beneficiation Plant	150,000 t/y concentrate with 30% grade
Khatoonabad Smelting	80,000 t/y anode copper
Leaching Plant	5000 t/y cathode copper

Table 7. Name and Capacity of Iran Refined Copper Producers

Source: Ministry of Industry, Mine and Trade

ROW	NAME	PROVINCE	NOMINAL CAPACITY
1	Rafsanjan Non Ferrous Recovery	Kerman	2,000 ton
2	Ghani Abad Comlex	Tehran	4,500 ton
3	Delijan Jahan Bam	Zanjan	260 ton
4	tcico	Kerman	1,000 ton
5	Miduk	Kerman	5,000 ton
6	Sarcheshmeh electrowinning	Kerman	7,000 ton
7	Sarcheshmeh refinery	Kerman	200,000 ton

12.3. IRAN COPPER SEMIFINISHED AND FINISHED PRODUCERS

12.3.1. BAHONAR COPPER COMPLEX INDUSTRIES

CSP is located 12 km from Kerman, in the vicinity of the largest copper mines in the Middle East. CSP has experienced tremendous growth and earned a worldwide reputation as a Regional industry leader since 1991. Currently CSP consists of the following four factories:

- Foundry Shop,
- Rolling Shop,
- Extrusion Shop, and
- Coin Blank Shop.

CSP production and inventories consists of sheets, strips, foils, tubes, rounds, hollows, rectangles, squares, hexagons, and made to or der shapes for customer specified applications. We are the leading copper alloy manufacturer and distributor of different grades of copper alloys in Iran.



Figure 88. CSP Complex

Source: csp.ir

- Foundry Shop

The foundry shop, built upon an area of 13,500 sq. meters, uses Krupp Industry technik GmbH (Germany) machinery, Wertli horizontal continuous casting furnaces and Outokumpu (Finland) technical knowledge. This factory has four melting and casting lines with electric induction and channel furnaces. 63000 tons of copper and copper alloys (such as brass, leaded brass, phosphorus bronze and cupronickel) can be produced in the foundry shop per annum. The products are divided into three main groups, named slab, billet and strip, which are in fact the incoming materials for rolling and extrusion shops.

The line 4 of this factory has the ability to continually cast strips with 14 by 500 mm. In this way it can afford for all the alloys which are problematic when produced by hot rolling or their cooling range is extended, such as leaded sheets and strips, phosphorus bronze and navy brasses.

Choosing and mingling the raw materials for alloy making is all done according to international standards. Material is identified in all stages of production, in scrap form, in molten form, in billet or slab form, and in final configuration. After melting process, a sample is send to the lab via a pneumatic post and after being verified by X-ray test the casting is done.

After passing the quality control, finally the casted products are tagged with batch numbers and identification numbers and is graded prior to dispatch.

- Extrusion Shop

Extrusion shop uses Mannesmann-Demag machinery from Germany and technical knowledge of Outokumpu of Finland. It is built upon 27,000 sq. meters area. This factory consists of two heavy extrusion press machines, pickling and annealing lines, spinners and drawing machines. The capacity of extrusion shop is 20,000 ton per annum and its product mix is including different types of square, hexagonal and round sections, tubes and bus-bars of copper and copper alloys. Such products are mainly used in:

- ✓ Oil and gas industries,
- ✓ HVAC industries,
- ✓ Electrical industries,
- ✓ Ship making industries,

Incoming raw material certificates are checked carefully to ensure it meets the required standard. The material is carefully checked as it moves down the production line until the final inspection. Coils and bundles of products are carefully tagged with batch numbers and identification numbers prior to dispatch.

High quality machinery has made CSP capable to hold tighter dimensional tolerances. Different packaging system is available according to the customer requirements.

All these products are backed by our dedicated technical support team, our stringent material control and qualification procedures, and our ability to trace and maintain batch history and integrity.

- Rolling Shop

Area of the Rolling Shop is more than 32,000 sq. meters. It has various rolling machines, annealing, furnaces, pickling lines, and slit ting and cut to length machines. Kobe Steel (Japan) has supplied the machinery and technology. The annual production of this factory is about 35,000 tons.

Incoming raw material certificates are checked to ensure it meets the required standard. The product is identified in all stages of production, in slab form, semi-finished form and in final configuration. Rolls are carefully tagged with batch numbers and identification numbers prior to dispatch.

Combination of high quality precision machinery and advanced computerized control system has made CSP enable to produce very smooth surface and precise thin copper sheets, while keeping tighter dimensional tolerances. Different sizes of copper and copper alloys sheets and strips are produced in rolling shop. Thin sheet up to 0.04 mm thickness can be produced and the maximum sheet width is 660 mm. Different packaging system is available according to the customer requirements

All of our products are backed by our dedicated technical support team, our stringent material control and qualification procedures, and our ability to trace and maintain batch history and integrity. This is why CSP is the most reputable name in the manufacture of copper and copper alloy sheet in Iran.

- Coin Blank Shop

Coin blank shop is built upon an area of 3,000 sq. meters area. This factory has two production lines, consisting of high speed Schuler press machine, vibratory deburring machines, edge rimming machine, continuous mesh belt annealing furnaces, high speed polishing machines, inspection machines, counter machines and packing system. The capacity of coin blank shop is 3,000 metric ton per annum.

Coins are mainly disc shaped and coinage material are usually from metals or metal alloys such as copper, aluminum, cupronickel, aluminum bronze, nickel silver, nickel brass, stainless steel, and etc.

CSP, as the sole producer of coin blank in Iran, is capable to manufacture blanks for different coin size and material based on customer demand. Both mono-metal and bi-metal coin blanks are producible in CSP plant.

The raw metal for coin blanks in rolled form can be manufactured in house, by using foundry shop and rolling shop facilities, or can be out sourced depend on the chemical composition and physical properties of the material.

Incoming raw material certificates are checked carefully to ensure it meets the required standard. The material is carefully checked at each station as it moves down the production line until the final inspection. Coin blanks are packed according to the client requirement and are carefully tagged with batch numbers and identification numbers prior to dispatch.

All of CSP products are backed by our dedicated technical support team, our stringent material control and qualification procedures, and our ability to trace and maintain batch history and integrity.

- Cast and Roll Tube Shop

Recently, CSP has commenced its totally new state-of-the art cast and roll tube plant. This plant has a significant amount of additional capacity utilizing horizontal casting and rolling processes. This shop is built upon 17,000 square meter area and with annual capacity of 10,000 tons of different sizes of seamless copper tubes. The manufacturing lines are purchased from SMS. (Germany) The whole production line is controlled by digital control systems and all tubes are checked by eddy current system.

Following two main groups of tubes can be manufactured in this plant.

- ✓ Smooth surface copper tubes.
- ✓ Inner grooved copper tubes.

Inner grooved tubes allows for a more efficient cooling / heating unit while reducing both energy consumption and costly demands from the unit's other components. This enables air conditioning OEM's to lower their costs through the production of smaller, more efficient cooling units.

Thin wall copper tubes manufactured in this plant will meet the most stringent international standards. Its precision and ability to hold tighter dimensional specifications allow for improved performance characteristics. In addition, its carefully

controlled annealing process introduces a new level of cleanliness and quality while our innovative packing solutions help to reduce customer costs.

CSP maintains its own laboratory to oversee all the chemical, mechanical, and physical properties of incoming materials and products. The product is identified in all stages of production, in billet form, molten material, semi-finished form and in final configuration. Rolls and bundles of products are carefully tagged with batch numbers and identification numbers prior to dispatch. [37]

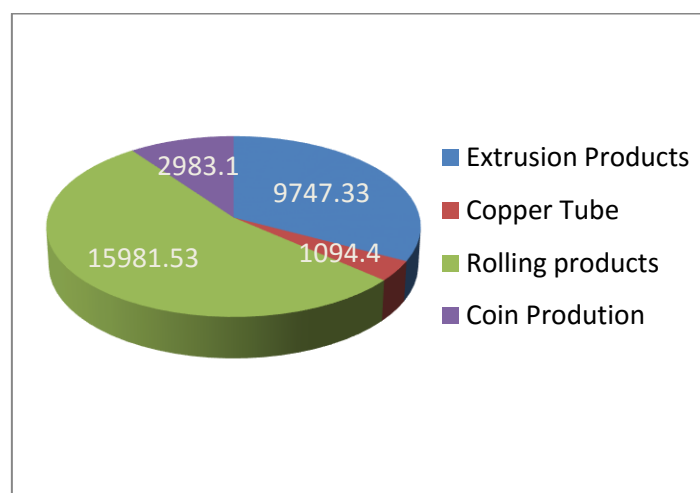

Figure 89: Copper Product of Bahonar copper Complex
Source: Annual report: 2014-2015

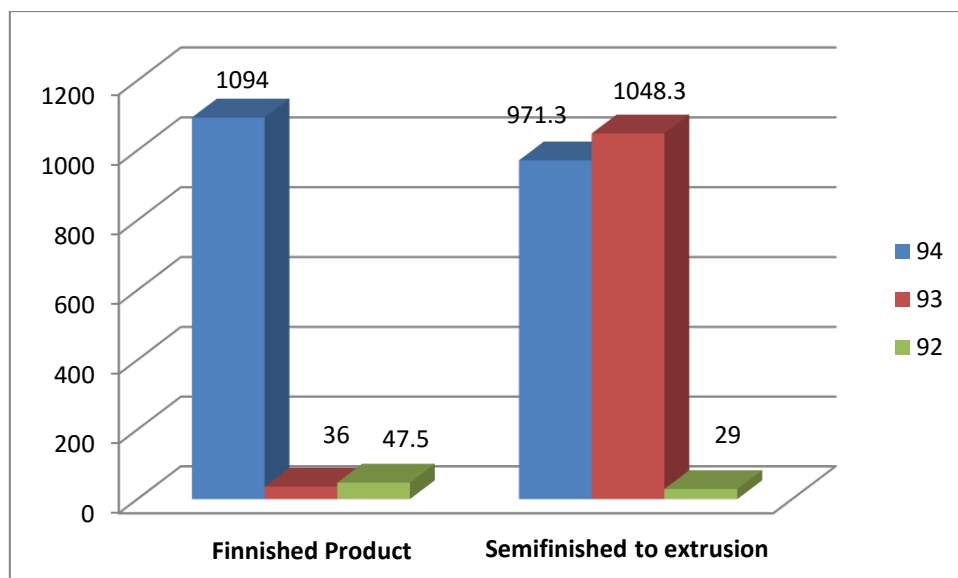

Figure 90: Copper Product of Bahonar copper Complex in different years
Source: Annual report: 2014-2015

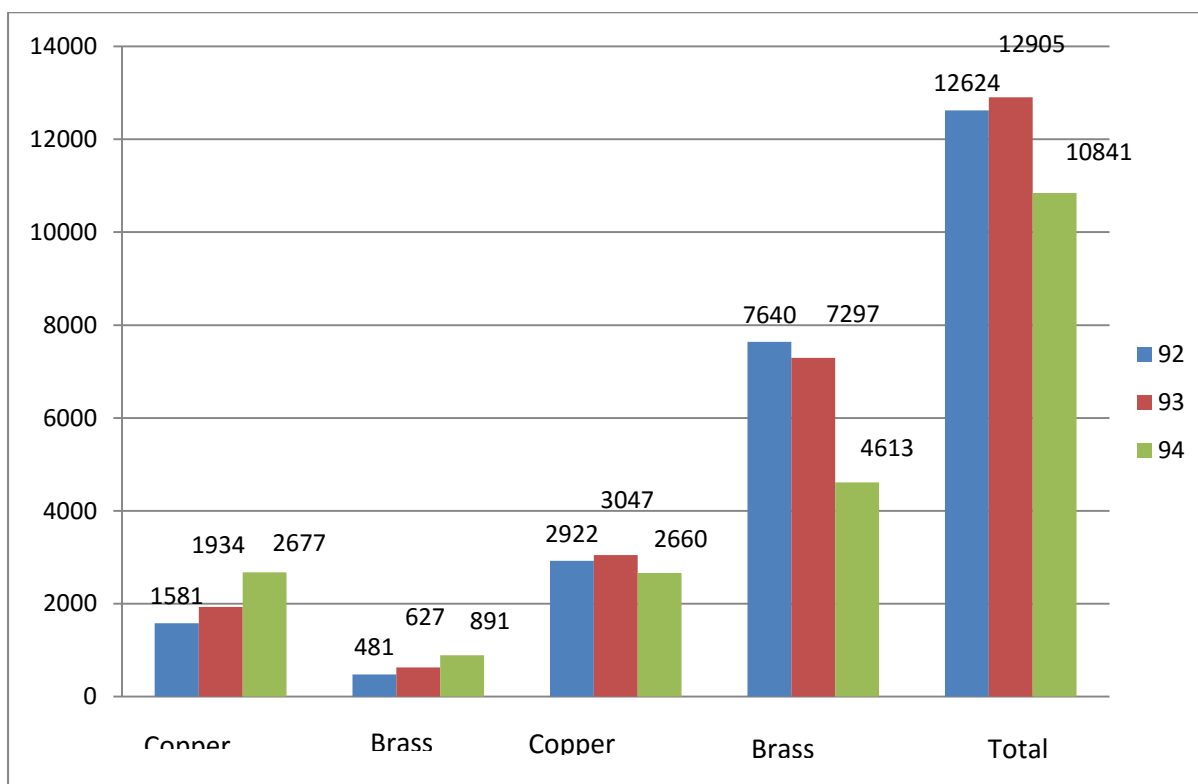

Figure 91: Copper Product of Bahonar copper Complex
Source: Annual report: 2014-2015

	Consumption in 93 (KWH/t)	Consumption in 94 (KWH/t)	Comparison between 93 & 94
Smelting and casting	776	813	+37
Extrusion	820	1091	+371
Rolling	746	784	+38
Copper tube	6059	7950	+1891
Coins	172	283	+111
Total	1911	2161	+250

Figure 92: Bahonar copper Complex Electricity Consumption
Source: Annual report: 2014-2015

	Consumption in 93 (m3/t)	Consumption in 94 (m3/t)	Comparison between 93 & 94
Smelting and casting	21.9	19.5	-2.4
Extrusion	71.8	70.5	-1.3
Rolling	108.3	111.9	+3.6
Copper tube	72	90.2	+18.2
Coins	67.6	67.9	+0.3
Auxiliaries	74.3	88.5	+14.2
Total	204.9	222.7	+17.8

Figure 93: Bahonar copper Complex Natural gas Consumption

Source: Annual Report: 2014-2015

	Consumption in 93 (m3/t)	Consumption in 94 (m3/t)	Comparison between 93 & 94
Total	20.5	22.9	+2.4

Figure 94: Bahonar copper Complex Water Consumption

Source: Annual Report: 2014-2015

12.3.2. SHAHR BABAK COPPER TUBE INDUSTRIES

Iranian Babak Copper Company (IBCCO) was newly founded and registered in Tehran. It is a subsidiary of Middle East Mineral Industries and Mines Development Holding Company (MIDHCO). Both IBCCO and MIDHCO are 100% private companies. There are two copper projects to be handled by IBCCO, namely Shahr-e-Babak Hydrometallurgy plant and copper tube plant.

IBCCO's fields of activities cover a wide range from copper mine to downstream products as following:

- Filed investigating and exploiting copper mines
- Mineral processing of small and medium size copper mine, establishment of copper plants – Cathode production using both pyro- and hydro- metallurgy processes.
- Establishment of downstream copper plants such as pipe and tubes, copper wire and rods, foils, profiles, ...

- Import and export of materials and goods, equipment and machineries for copper projects.
- Technical supervision, management and commercial activities in the above mentioned fields

Ongoing Projects:

A 12,000 tpa copper tube production using up-cast technology. Similarly, several options were studied and both local and regional markets were studied and copper pipes and tubes have been selected as first product to be produced by IBCCO. Among several downstream copper factories, board of directors approved to conduct a copper tube plant using up-cast and ASMAG equipment. Other products will be produced in next phase. Construction years are two years and capital investment is estimated to be around US\$ 30,000,000. Produced copper tubes will be of best quality and up to 80% of it shall be exported to countries such as UAE, Saudi Arabia and Turkey. [38]

12.3.3. COPPER WORLD COMPANY

Copper World Company was established in 2001 and has experienced rapid growth due to the excellent vision of management and constant commitment to quality, build in 52000 sq. meter area and 18000 sq. meter covered space in Kashan 220 kilometer south from Tehran. Total production capacity of plant exceeds 160000 tons per year.



Figure 95. Copper World Company

Source: copperworld.net

Currently Copper World Company is the biggest in the country and one the biggest in the Middle East. Copper World Company also has drawing machines with the most up to date technologies all bought from well known European companies. Copper World quality control unit test the performance of product to meet the requirement of appropriate standards. High tech test machines such as Spectrometer, Oxygen Analysis, Tensile, Conductivity meter, Thickness tester and Metallurgical Microscope are used to control the quality. [39]

12.3.4. MEHRASL

Since 1990, MEHRASL Manufacturing Corporation ranks among the Leading Manufacturers of Air- Conditioning & Refrigeration Systems, Copper Tubes, Copper Fittings, Insulation Material and other HVACR parts for residential, industrial and commercial applications in the Middle East.

MEHRASL has installed its own concentration plant in 40 hectares space in its own mine courtyard.

The diligent and Innovative managers along with up to 1,000 employees stand behind this success. People who put all of their energy into making sure that air-conditioning will be perfect with their products everywhere and every time.

Headquartered in Tehran, set up Manufacturing Plants in Tabriz, East Azerbaijan Province, Iran spanning 120,000 m² with a wide range of products, MEHRASL is able to meet with the requirements of the largest air-conditioning and construction projects.

ACR Copper Tubes:

- * Level Wound Coils (LWC)
- * Straight Length Tube
- * Pancake Coils
- * Inner Grooved Tube
- * Finned Tubes

Pre-Insulated Copper Tube:

- * Straight Length Copper Tube coated with insulation 9mm & 13mm
- * Pancake Coils coated with insulation 9mm & 13mm

Copper Fittings:

- * U Bend, Equal Tee, Equal Coupler, Reducer, Elbow 45°, and Elbow 90° and ... [40]

12.3.5. QAEM COPPER INDUSTRIES

Qaem Copper Industries Co. is the first and largest manufacturer of seamless copper tube with C & R technology in Iran. It has been founded in 1380 in the industrial zone of Moorchehort. Now the company has an annual production capacity of 24,000 tons of copper pipes needed for domestic market. C & R technology was first developed in 1992 and this company is the first and biggest producer of copper tubes with this method in Iran. This method has the advantages such as higher quality of products, more variety in sizes and thicknesses which can be produced, the production of tubes with less external diameter and wall thickness more concentric in internal and external pipe sections compared to extrusion method. [41]



Figure 96. Qaem Copper Industries

Source: qaemcopper.com

12.3.6. KAVEH COPPER COMPANY

The company consists of two units casting rod from Scrap (Scraped wire and cable) Casting of rod from cathode. Company nominal capacity increased in 1388 to 72 thousand tons per year.

12.3.7. MESBAR KAVEH COPPER COMPANY

This company was established in 2001 in Kaveh Industrial Zone to supply domestic electric industry. The capacity of this company is 5,000 ton per year copper rod.

12.3.8. MESKARAN COPPER COMPANY

This Company has two lines of casting lines with 10,000 ton capacity.

12.3.9. OFOGHE ALBORZ COMPANY

Ofoghe Alborz produces electrical cable for high and medium voltage uses. The capacity of the company is 70,000 ton per year copper rod.

12.3.10. SIMKAT TABRIZ COMPANY

The capacity of this company is 7,000 ton per year pipe, rod and copper strip.

12.3.10. ELECTRO MES COMPANY

This company has extrusion equipment and its capacity is 1000-1500 ton busbar.

13.SUPPLY AND DEMAND

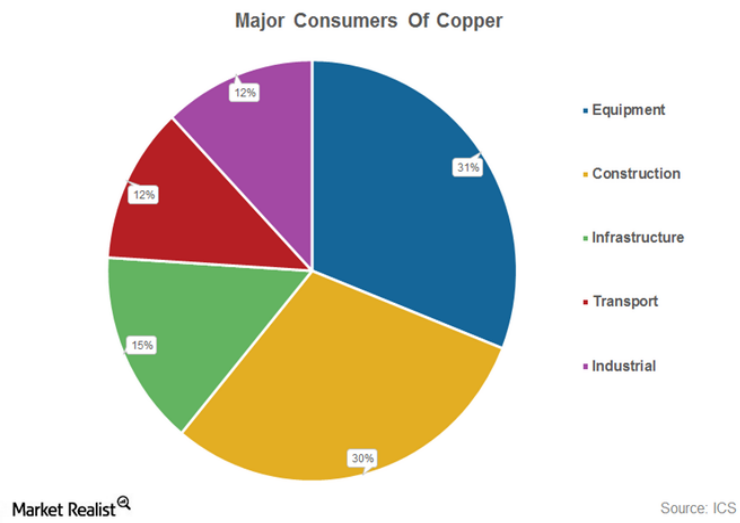

Figure. 97: Major Consumers of Copper
Source: ICSG

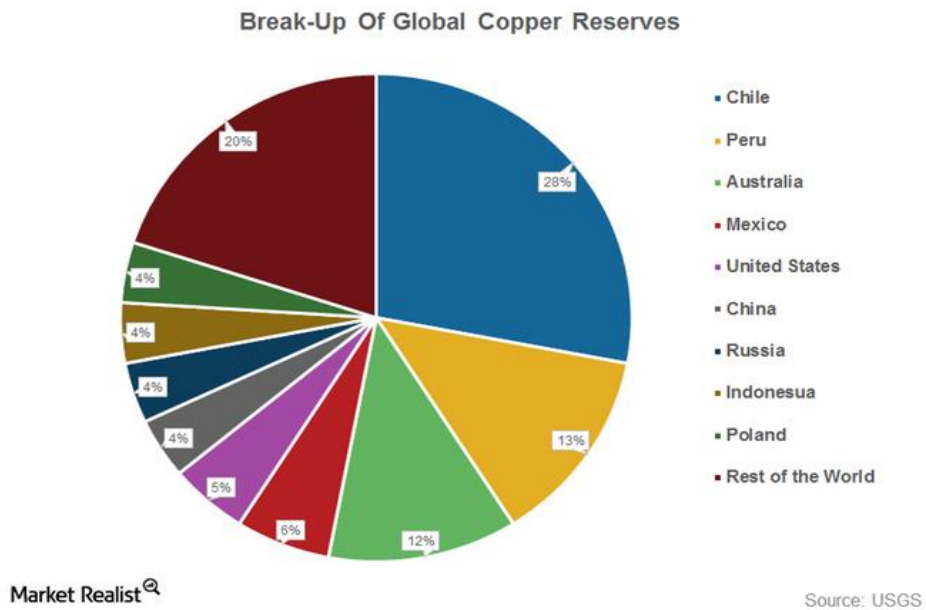

Figure. 98: Global Copper Reserves
Source: ICSG

Breakup Of Global Copper Consumption

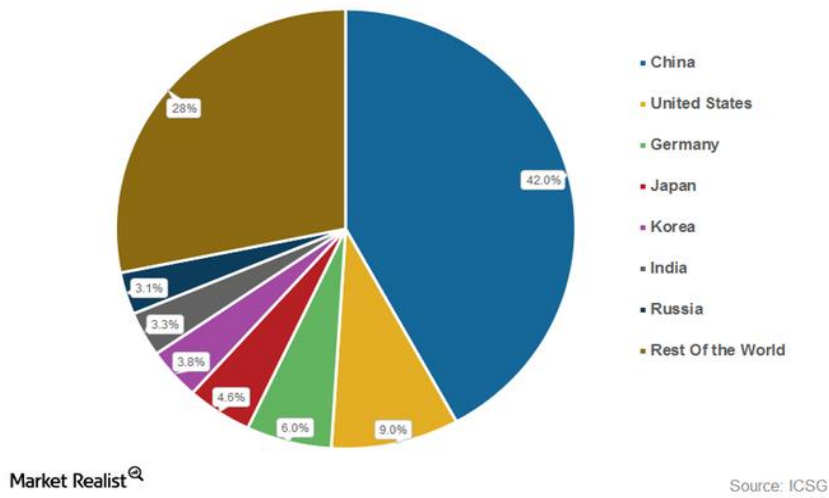

Figure. 99: Global Copper Consumption
Source: ICSG

Historic Copper Metal Prices & Stocks 



Figure 99. Daily Copper Prices and Stocks
Source: LME, ICSG, ILZSG

14. COPPER IMPORT & EXPORT

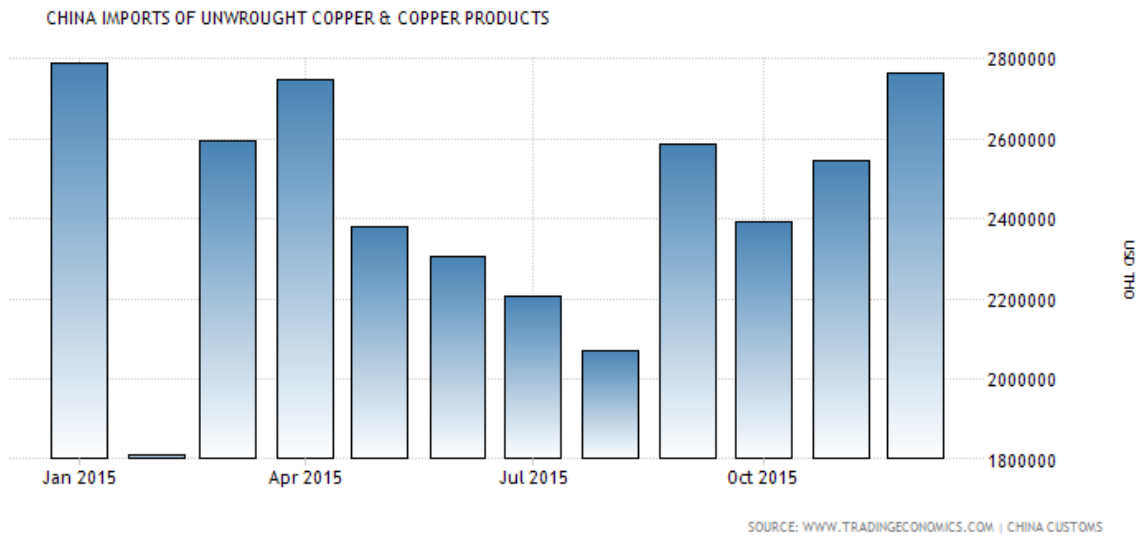

Figure 99. China Imports of Unwrought Copper & Copper Products
Source: tradingeconomics.com

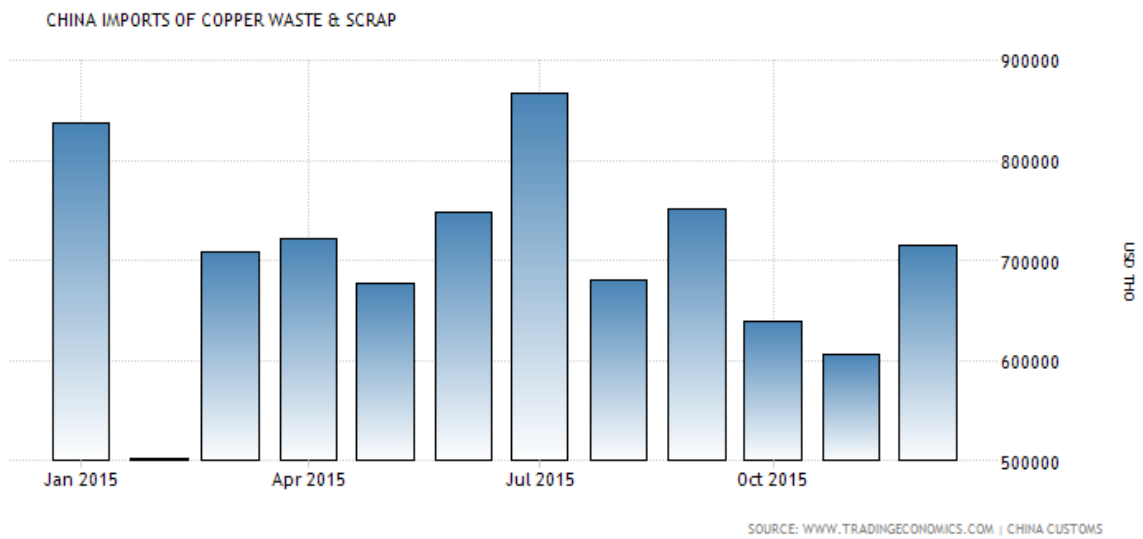

Figure 100. China Imports of Waste & Scrap
Source: tradingeconomics.com

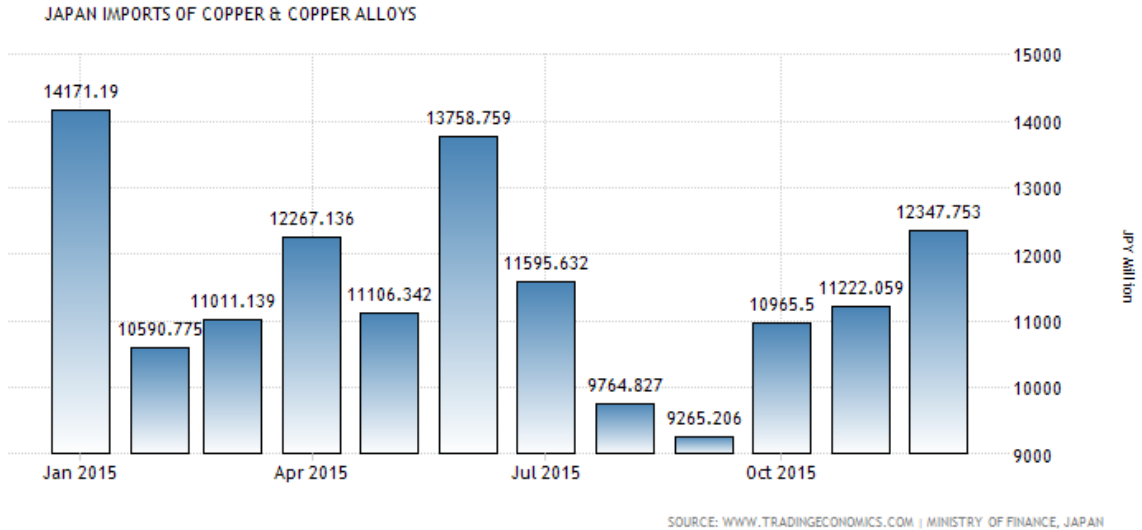

Figure 101. Japan Imports of Copper & Copper alloys
Source: tradingeconomics.com

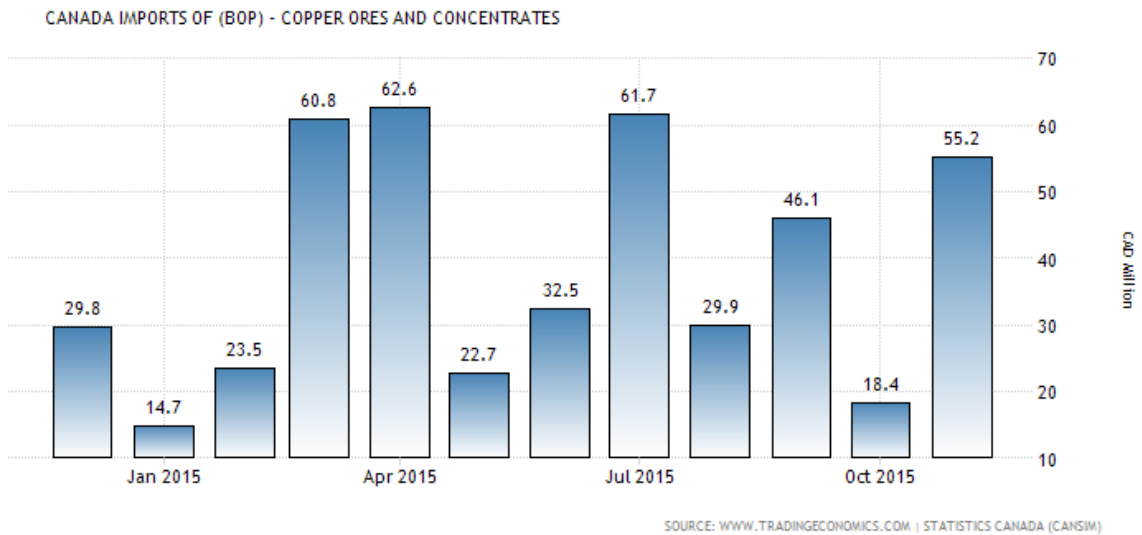

Figure 102. Japan Imports of (BOP) Copper Ores & Concentrates
Source: tradingeconomics.com

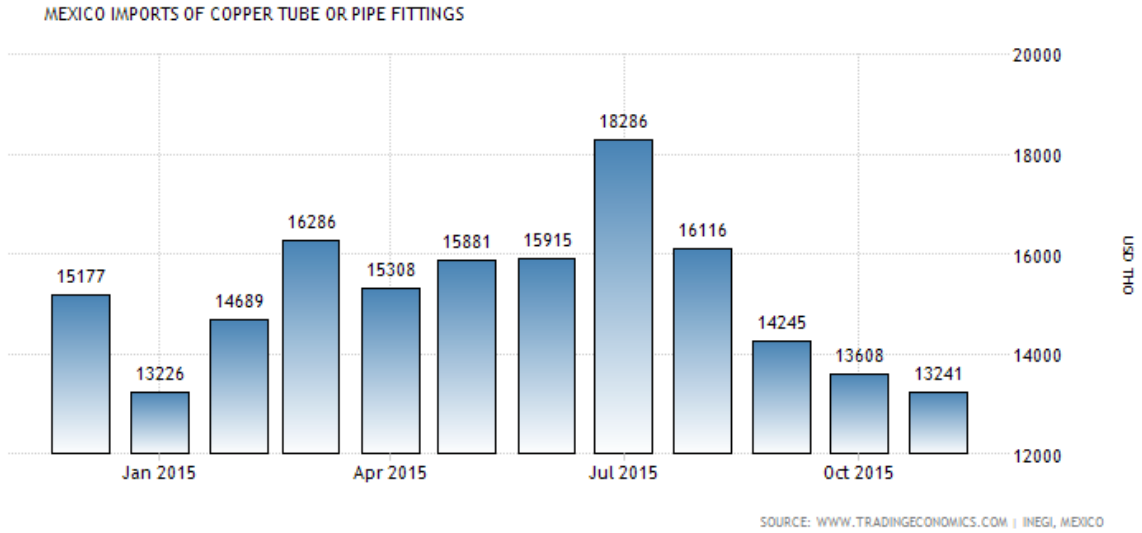

Figure 103. Mexico Imports of Copper tube & pipes Fittings
Source: tradingeconomics.com

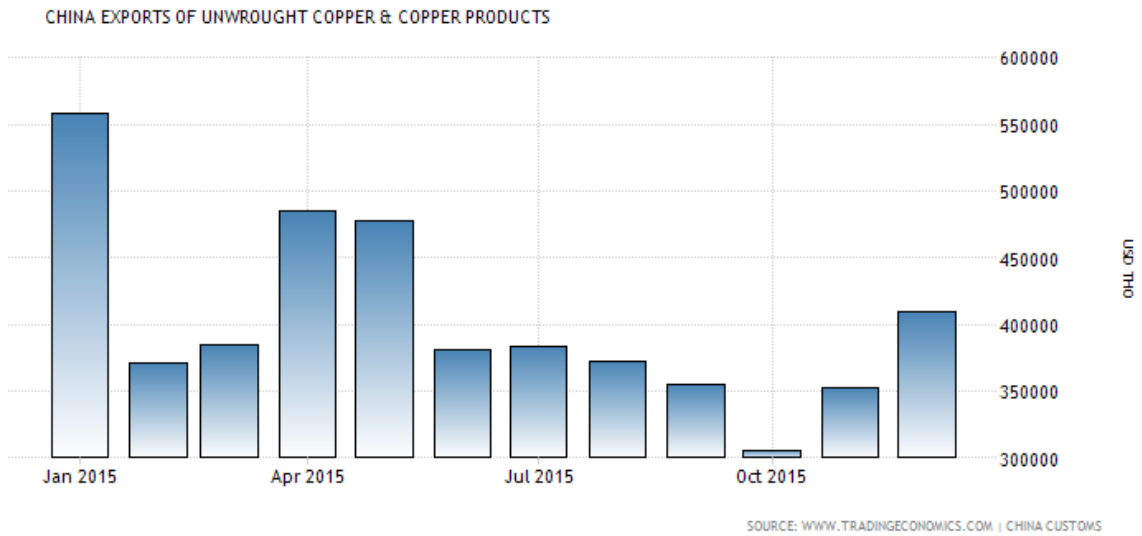

Figure 104. China Exports of Unwrought Copper & Copper Products
Source: tradingeconomics.com

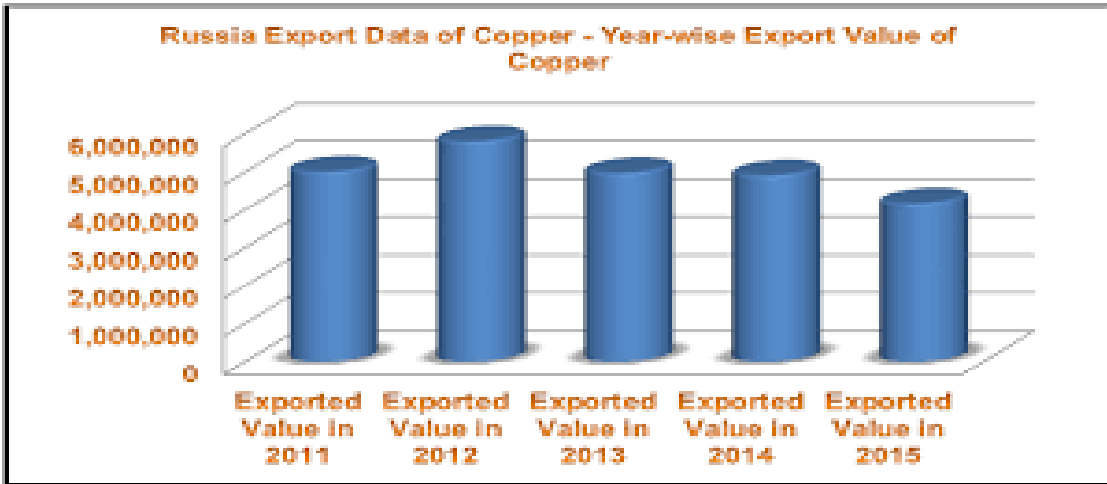

Figure 105. Russia Exports of Copper

Source:

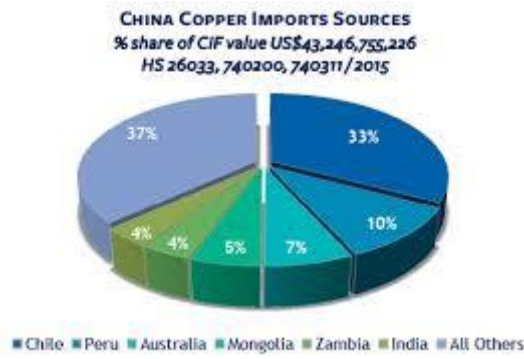

Figure 106. China Copper Imports Sources

Source:

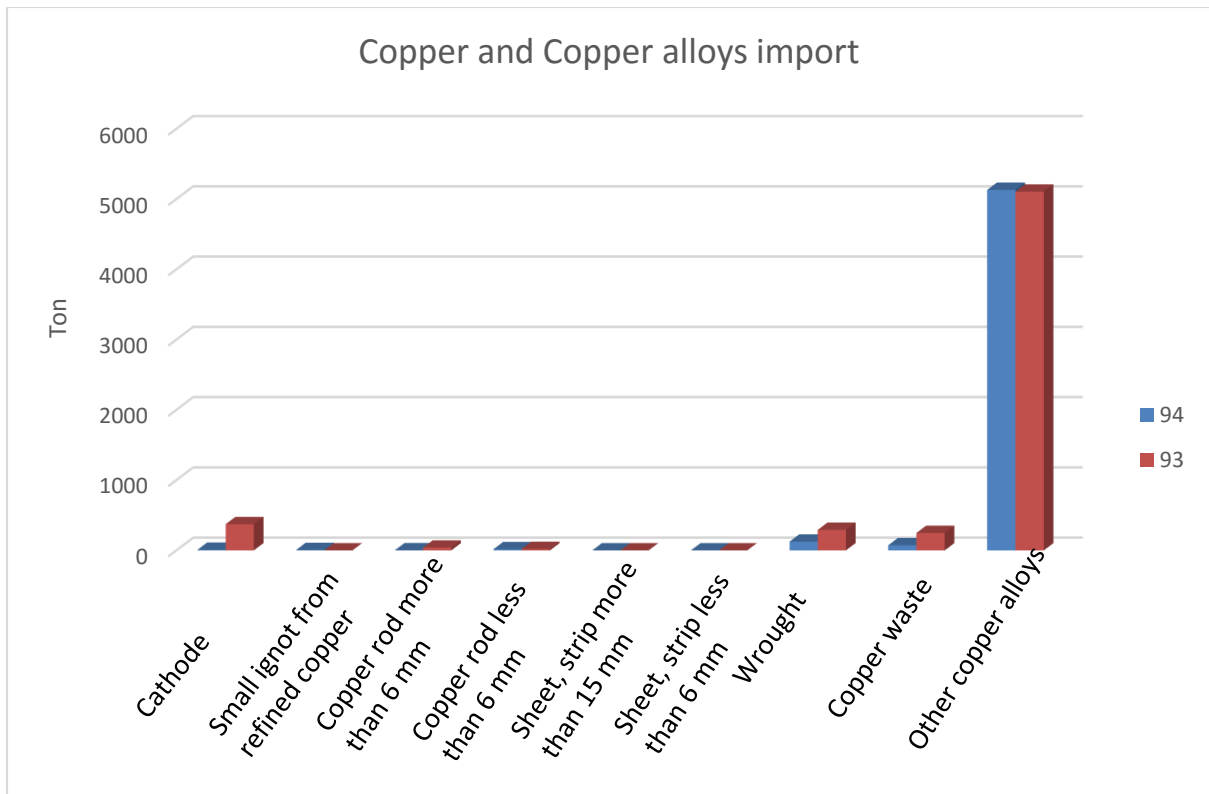

Figure 107. Iran Copper Imports (ton) in Two Months
Source: Cvelexkala

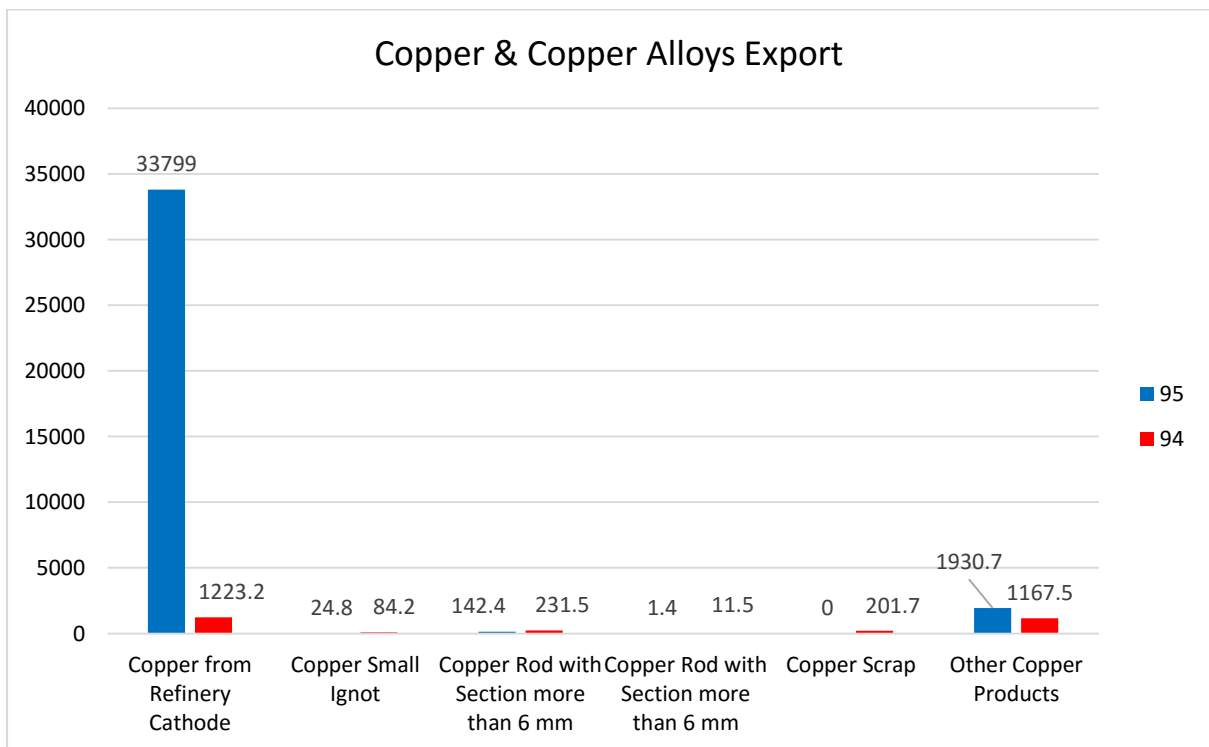

Figure 108. Iran Copper Export (ton) in Two Months
Source: Cvelexkala

Period	Trade Flow	Reporter	Partner	Trade Value	NetWeight (kg)	Trade Quantity
2011	Export	Iran	World	\$47,050,150	241,421,364	241,421,364
2011	Export	Iran	Philippines	\$19,689,618	113,158,733	113,158,733
2011	Export	Iran	China	\$16,923,141	67,565,934	67,565,934
2011	Export	Iran	Rep. of Korea	\$5,295,811	30,435,697	30,435,697
2011	Export	Iran	India	\$5,096,899	29,292,516	29,292,516
2011	Export	Iran	Georgia	\$44,681	968,484	968,484
2010	Export	Iran	World	\$32,212,799	181,659,655	181,659,655
2010	Export	Iran	India	\$26,110,632	150,063,404	150,063,404
2010	Export	Iran	South Africa	\$3,393,038	19,500,217	19,500,217
2010	Export	Iran	Philippines	\$1,655,365	9,513,592	9,513,592
2010	Export	Iran	China	\$1,052,318	2,551,555	2,551,555
2010	Export	Iran	Georgia	\$1,436	30,724	30,724
2010	Export	Iran	United Kingdom	\$10	163	163

Figure 109: Iran Copper ores and concentrates

Source: UN Comtrade

15. COPPER PRICES



Figure 110. One Month Copper Prices and Price Charts

Source: infomine.com



Figure 111. Six Months Copper Prices and Price Charts

Source: infomine.com



Figure 112. One Year Copper Prices and Price Charts

Source: infomine.com



Figure 113. Five Years Copper Prices and Price Charts

Source: kitco.com

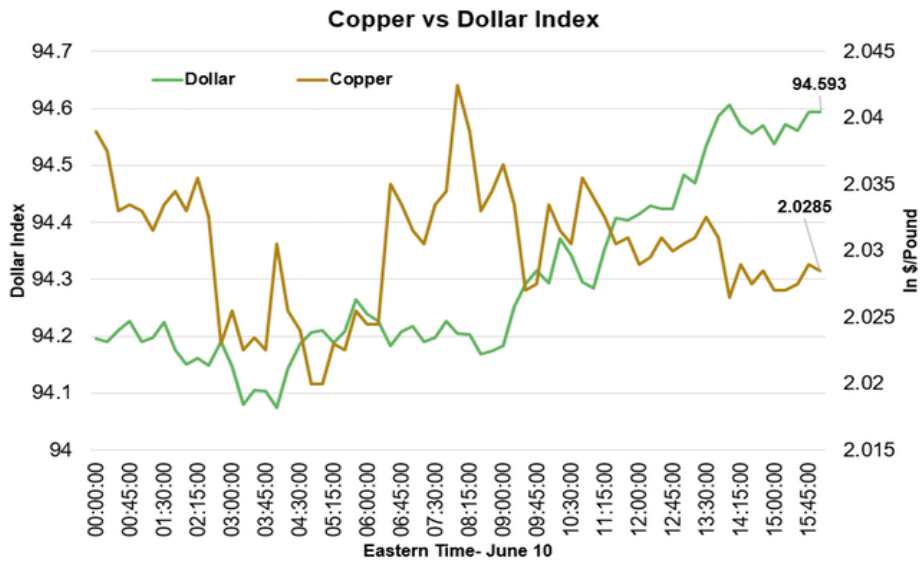

Market Realist[®]

Sources : COMEX & ICE

Figure 114. Copper Vs Dollar Index

Source: COMEX & ICE

16. DEVELOPMENT PLANS

16.1. KHATOON ABAD SMELTER EXPANSION

Client:	National Iranian Copper Industries Company
Consultant:	Company Kahnrbra
Main contractor:	Copper Mining Company
Management contract:	Perman scanning
Technologist:	Outotec Finland
Start date:	1390
Duration:	72 months
Capacity:	120000 t/y

16.2. SARCHESHMEH NICKEL PLANT

Client:	National Iranian Copper Industries Company
Technologist:	
Start date:	1391
Progress:	65%
Capacity:	345 kg/d Nickel Cathode

16.3. CHEHEL KOREH COPPER PROGRAM

Place	south-west of Zahedan city
Minable reserve	about 3 million ton with average grade of %1.39
Client	National Iranian Copper Industrial Company
Capacity:	Copper ore (300,000 Tons) and Copper ore concentrate (16,670 ton)

16.4. MAHURE CHAH KALEH PROSPECT

Place	Ardestan
Project	Exploration project of Mahure Chah Kaleh prospect
Client	National Iranian Copper Industrial Company

16.5. LORDKHIZAN PROSPECT

Place	Anbarabad
Project	Exploration project
Client	National Iranian Copper Industrial Company

16.6. THE GROUH PROSPECT

Place	Kerman
Project	Exploration project
Client	National Iranian Copper Industrial Company

16.7. SINABAD PROSPECT

Place	Jiroft
Project	Exploration project
Client	National Iranian Copper Industrial Company

16.8. ZAVORK PROSPECT

Place	Jiroft
Project	Exploration project
Client	National Iranian Copper Industrial Company

16.9. RAZI ABAD PROSPECT

Place	Jiroft
Project	Exploration project
Client	National Iranian Copper Industrial Company

16.10. DAREH HAMZEH PROSPECT

Place	Jiroft
Project	Exploration project
Client	National Iranian Copper Industrial Company

16.11. PURCHANGI PROSPECT

Place	Zahedan
Project	Exploration project
Client	National Iranian Copper Industrial Company

16.12. BIDESSTAR PROSPECT

Place	Zahedan
Project	Exploration project
Client	National Iranian Copper Industrial Company

16.13. BAGH GOLAN PROSPECT

Place	Jiroft
Project	Exploration project
Client	National Iranian Copper Industrial Company

16.14. BAB SHAMIL PROSPECT

Place	Bardsir
Project	Exploration project
Client	National Iranian Copper Industrial Company

16.15. BAGH GOLAN PROSPECT

Place	Jiroft
Project	Exploration project
Client	National Iranian Copper Industrial Company

16.16. LAR DEPOSIT

Place	Zahedan
Project	Cu concentrate (grade ~%26) - 3,600 (ton per year)
Client	National Iranian Copper Industrial Company

16.17. KAHANG DEPOSIT

Place	Ardestan
Project	Cu concentrate (grade ~%26) - 3,600 (ton per year)
Client	National Iranian Copper Industrial Company

16.18. KHATOON ABAD REFINERY PLANT

Place	Khatoon abad
Project	Refinery plant
Capacity	200,000 t/y
Technology	Electrorefining

16.19. KHATOON ABAD ACID SULFURIC PLANT

Place	Khatoon abad
Project	Acid sulphuric
Capacity	750,000 t/y

16.20. KHATOON ABAD OXYGEN PLANT

Place	Khatoon abad
Project	Oxygen plant
Capacity	750 t/d

16.21. KHATOON ABAD OXYGEN PLANT

Place	Khatoon abad
Project	Lime plant
Capacity	500 t/d

16.22. SARCHESHMEH BENEFICIATION EXPANSION_PHASE 2

Place	Sarcheshmeh
Project	Expansion of beneficiation

16.23. SARCHESHMEH BENEFICIATION EXPANSION_PHASE 3

Place	Sarcheshmeh
Project	Expansion of beneficiation

16.23. SUNGUN BENEFICIATION EXPANSION_PHASE 2

Place	Sungun
Project	Expansion of beneficiation

16.24. MIDUKN BENEFICIATION EXPANSION_PHASE 2

Place	Miduk
Project	Expansion of beneficiation

16.25. SUNGUN BENEFICIATION EXPANSION_PHASE 3

Place	Sungun
Project	Expansion of beneficiation

16.26. SARCHESHMEH SLAG FLOTATION

Place	Sarcheshmeh
Capacity	73,000 ton/y

16.27. SUNGUN SLAG FLOTATION

Place	Sungun
Capacity	43,000 ton/y

16.28. KHATOONABAD EXPANSION OF SMELTING

Place	Khatoon abad
Capacity	Increasing to 200,000 t/y

16.29. KHATOONABAD SULPHURIC ACID PLANT

Place	Khatoon abad
Capacity	750,000 t/y

16.30. SUNGUN SMELTING PLANT

Place	Sungun
Capacity	200,000 t/y

16.31. SUNGUN SULPHURIC ACID PLANT

Place	Sungun
Capacity	750,000 t/y

16.32. SUNGUN REFINERY PLANT

Place	Sungun
Capacity	200,000 t/y

16.33. KHATOONABAD REFINERY PLANT

Place	Khatoon Abad
Capacity	200,000 t/y

Changing Reverb technology to flash and gas recovery of smelting plant with 280,000 ton per year capacity	
Place	Sarcheshmeh
Start year	1388
Concentrate Input	1,250,000 ton per year with grade 25%
Predicted Operating time	Smelting: 1395 Dedusting:1396
Consultant	(Hezar Sanat, Aria Hengard, Kavoshgaran)
Technologist	Outotec
Contractor	Tiv energy,Bam Rah, Mobina Takjoo, Fakoor
Investment	201 million Euro 3,700 billion Rial
Investment till now	141 million Euro 2,355 billion Rial
Progress	Smelting:84.83% Gas recovery system:81.5%

Optimizing flash technology and gas recovery of smelting plant with 120,000 ton per year capacity	
Place	Khatoon Abad
Start year	1389
Concentrate Input	485,000 ton per year with grade 25%
Predicted Operating time	Concentrate warehouse: 1395 Oxygen:1395 Smelting:1396
Consultant	Kahanroba
Technologist	Linde for oxygen plant, Outotec for smelting
Contractor	Bam Rah, Energy Sanat for oxygen, Moshiran and Ronin for concentrate warehouse, Kani Mes for smelting
Investment	109 million Euro 1,330 billion Rial
Investment till now	46 million Euro 875 billion Rial
Progress	Concentrate warehouse: 96.87% Oxygen: 88.03% Increasing capacity of smelting: changing in capacity from 200,000 to 120,000 ton

Acid Sulphuric Plant for Sarcheshmeh: 610,000 ton per year Khatoon Abad: 600,000 ton per year	
Place	Sarcheshmeh, Khatoon Abad
Start year	1390
Predicted Operating time	1397
Consultant	Nipec
Technologist	Outotec
Contractor	Fan Avaran Parsian, Rampco
Investment	164 million Euro 880 billion Rial
Investment till now	5 million Euro 520 billion Rial

17. CONCLUSION

Experts in base metals field believes that copper future will improve in long term and copper prices will increase. Despite the fact that over the past year, prices for most mineral products had tended to decline. The reasons for the decline in prices of base metals during this period depends on various factors such as:

- Slowdown in global economy
- Reduce in China consumption
- Exchange rate of the dollar against other currencies
- Decline in global demand
- Not enough economic growth in emerging countries up to the predicted level

Marketwatch reports announced of increased physical demand in not far future to buy basic metals such as copper on world markets, which will increase the price of these products. The report of America geology organization also shows, Chile, the largest copper producer in 2015 produces 5 million and 700 thousand tons of copper which is 50 thousand tons less than last year. After Chile, China, Peru and America are the world's leading producers.

Experts predict by the end of 2016, the copper market will be faced with excess production of 300 thousand tons. According to some analysts, if China economy improves in future months coming months if economic conditions improve, coinciding with the growth of the dollar, the relative growth in the price of copper and other metals will be essential.

According to surveys conducted by the analysts, the copper price will increase in future and according to this estimate, the increase in copper price by the end of 2016 and also in 2017, although slow but will be stable.

Experts say there is a relationship between copper price on world market and China's economic growth.

Two Fundamental in mineral industry market now is decline in China's imports of raw materials and energy on one hand and increasing in world mines production on the other which causes decrease in Copper price.

According to the vision about prices countries should focus on improving productivity and increasing competitiveness for a prolonged period adopted to decreasing price procedure in the mining sector.

In the condition of decreasing the price, the company is successful which can decrease its production price to keep its competitiveness. Copper production in Iran is

not an exception and should be based on a policy to increase efficiency and reduce costs.

Weather problems in Chile which was unprecedented in the past 70 years, has inflamed copper market. If these events continue, the copper market will be faced fluctuation.

The high cost of some mines extracting cause them to be shut down, causing shortages of raw materials for copper production lines.

At the same time, high-grade mines are finishing and new mines have not the quality of previous mining. All this will increase the price of copper by 2020.

2020 will be the peak of China's copper market. Also returning scrap copper in China since 2020 will be increased and will cause the production of copper with more suitable cost than before.

It has been forecasted that in 2020 Copper will challenge with decreasing the price. But some believe that by 2020, India will be a leading copper consumer countries most likely will fill the blank of China's consumer market especially because India does not have infrastructure of copper production like China.

Based on previous studies in country, the most profit in copper chain, is concentrate and export of concentrates is the most profitable option for manufacturers. But certainly with the benefit of added value is different. But the benefit differs with added value. In terms of the national economy, completion and production of Copper chain, production of ingots and increasing downstream copper products would be the best choice.

Perhaps with chain development, to copper ignots, the profit will be reduced to some extent but the presence of copper in downstream industries, the profit will increase.

The most important phenomenon in development of industrial chain, is creating sustainable jobs and confident exports which causes increasing in GDP. It seems that manufacturers of Copper in Country, together with planning to reduce cost of product should be developed downstream industries characterized in terms of quality and price competitiveness.

REFERENCES:

1. Copper, <http://weppi.gtk.fi/publ/foregsatlas/text/Cu.pdf>
2. Corrosion Behavior of Copper Alloys in Seawater with emphasis on UNC C95700, D.Nazeran, S.T. Talebian and I. Sadr, Technical Journal of Engineering and Applied Sciences, 2013, PP:293-286
3. USGS Mineral Resources Program, Copper-A Metal for the Ages, Jeff Doebrich, 2009
4. Facts about Copper, Copper Uses, Resources, Supply, Demand and Production Information, Republished from USGS Fact Sheets released in June, 2009 and January 2014
5. <https://www.coppermasters.com>
3. The Copper Advantage, A Guide to Working with Copper and Copper Alloys, Copper Development Association
4. Discrimination between mineralized and barren copper porphyry using temperature data, T. Habibi and A. Hezarkhani
5. Geochemistry, mineralization and alternation zones of Darreh Zar Porphyry Copper deposit, Kerman, Iran, R. Derakhshani and M. Abdolzadeh, Journal of applied science, 1628-1646, 2009
6. http://www.aalco.co.uk/datasheets/Copper-and-Copper-Alloys-Introduction-to-copper-and-its-Alloys_68.ashx
7. European Copper Institute Annual Report, 2015
8. <http://www.copper-tubes.net/advantagescopper.html>
9. The Copper Advantage: A Guide to Working with Copper and Copper Alloys
10. <http://www.copperalliance.org/>
11. Porphyry Copper Assessment of the Tethys Region of Western and Southern Asia, Global Mineral Resource Assessment, Scientific Investigations Report 2010–5090–V, USGS
12. Ullmann's Encyclopedia of Industrial Chemistry, 2001
13. Technical Resources Document, Extraction and Beneficiation of Ores and minerals, Volume 4, Copper
14. Processes to produce copper and its alloys from primary and secondary raw material, uerometaux
15. <http://www.otto-fuchs.com>
16. Copper wire factory

17. <http://www.garrisonminerals.com>
18. Copper Mining, chemical reactions, <http://resources.schoolscience.co.uk>
19. Semi-finished products in copper and copper alloys – Basic element of power engineering, Wieland
20. Copper Tube Handbook, CDA Publication A4015-14/16
21. The Life Cycle of Copper, its Co-Products and By-Products, Robert U. Ayres, Leslie W. Ayres and Ingrid Råde
22. Recycling of Copper, Copper development association inc.
23. Copper Recycling and Sustainability, Benefits of recycling
24. Methods and Techniques for Recycling Copper
25. Types of copper scrap
26. <http://www.mining-technology.com>
27. Introduction to largest copper mines of the world, Ali Akbar Razavi, 1394
28. <http://www.mobinco.com>
29. www.nicico.com
30. <http://www.parsolang.com>
31. Reserve evaluation of Darreh Zereshk copper deposit, 21th symposium on geosciences
32. Iran Daily, July 2010
33. <http://mespress.ir>
34. Discrimination between mineralized and barren copper Porphyry Deposits using temperature data, T. Habibi, A. Hezarkhani, Amirkabir university of Tehran, T. Habibi and A. Hezarkhani
35. <http://www.qalehzarimine.com>
36. http://www.ngdir.ir/Data_SD/Plants/Files/chehargonbad.pdf
37. http://www.csp.ir/index_en.html
38. <http://ibcco.midhco.com/>
39. <http://www.copperworld.net/>
40. <http://www.mehrasl.org/>
41. <http://qaemcopper.looleh.ir/en>